

Additional Explanations – Lecture 8 – Linked Stacks and Queues

Push a new node onto an empty stack:

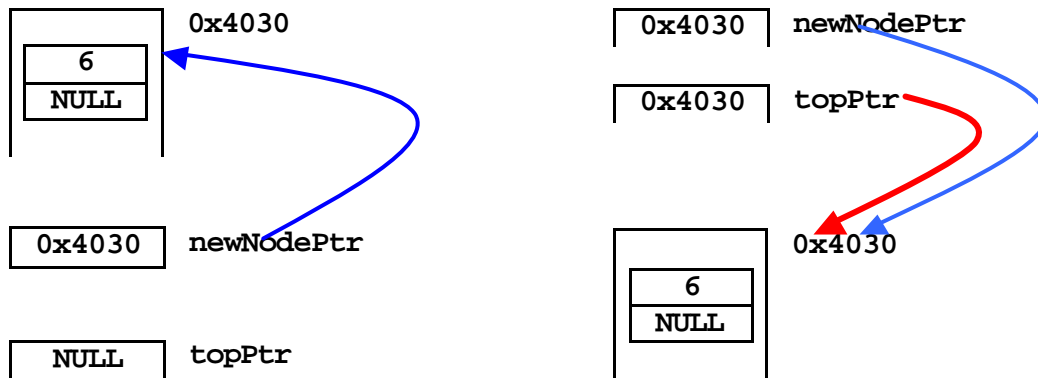

CSE1303 Part A – Data Structures and Algorithms

Normal push:

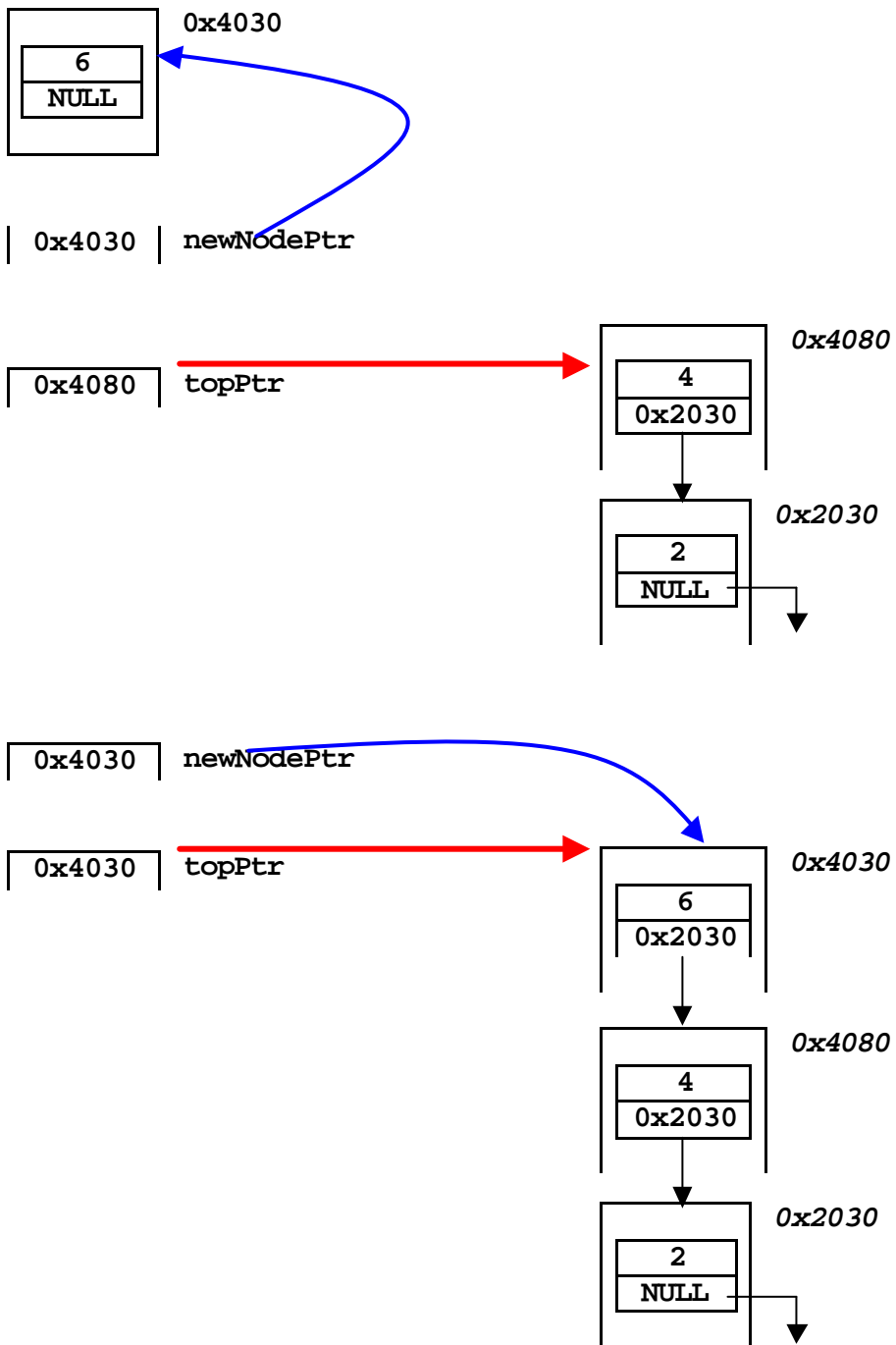

NOTE: you need to change the `next` member of the new node, **before** you change the `topPtr` to point to that new node!

CSE1303 Part A – Data Structures and Algorithms

Pop an item off the list:

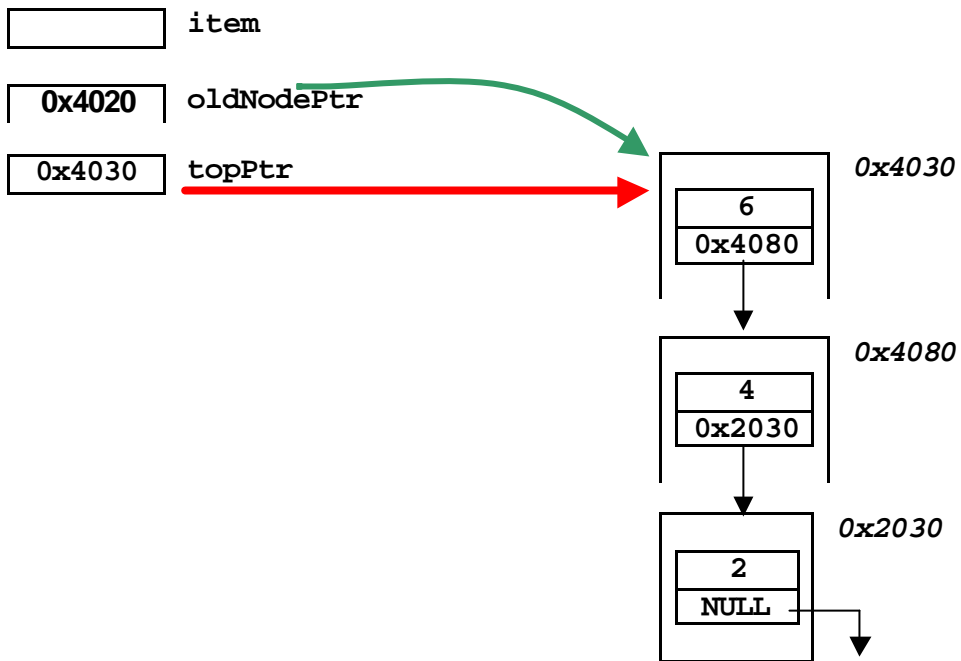

...

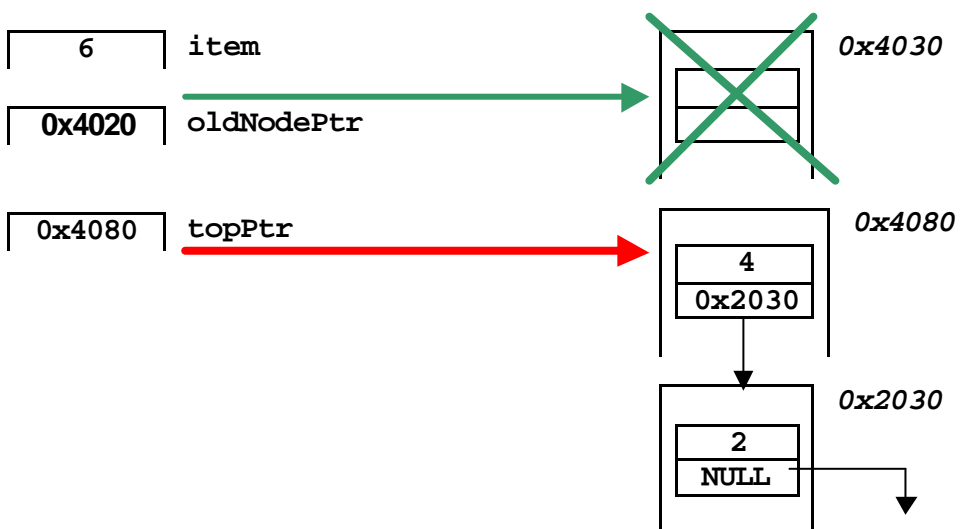

Note: you need to remember where the top node was, so you can free that memory. You need to move the `topPtr` **before** you free the memory.

CSE1303 Part A – Data Structures and Algorithms

Append a new node to the empty Queue:

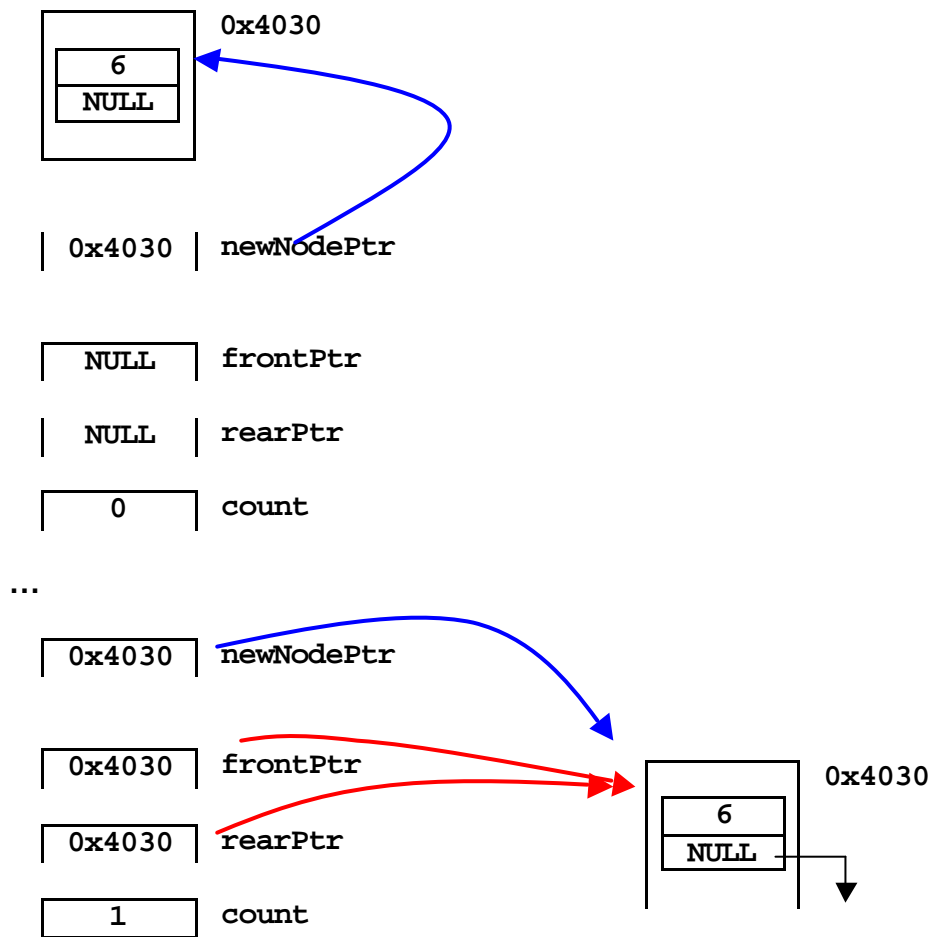

Note: you have to set both `frontPtr` and `rearPtr` to the new node.

CSE1303 Part A – Data Structures and Algorithms

Append a new node to the queue

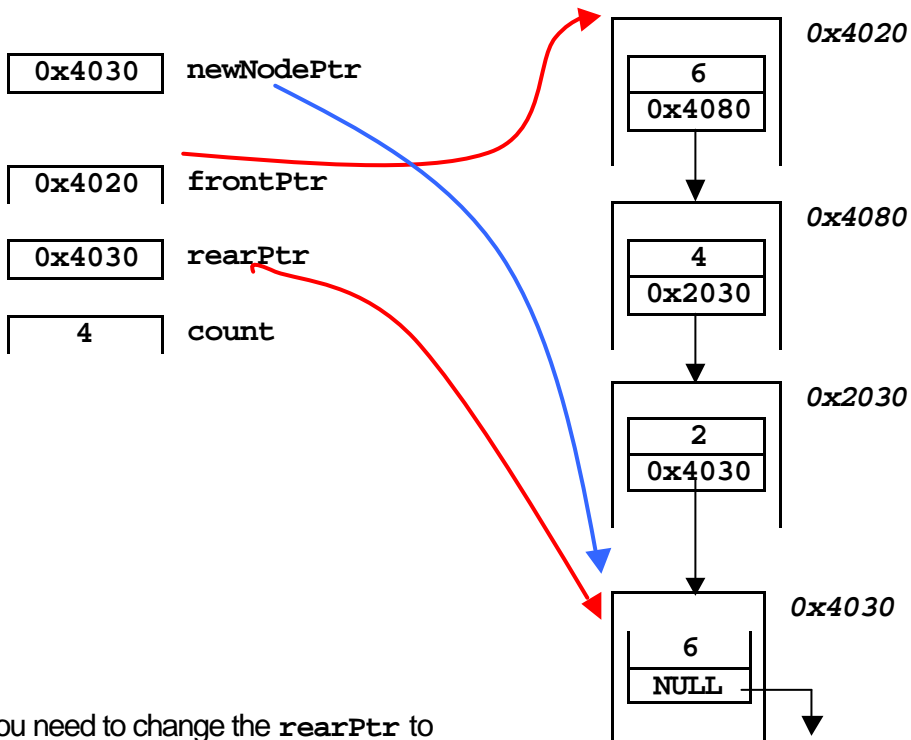
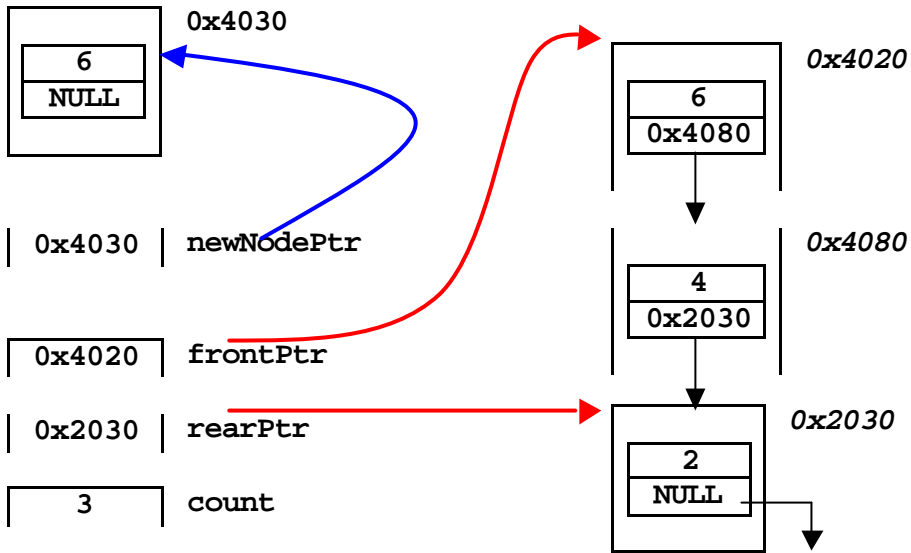

You need to change the `rearPtr` to point to the new node.

CSE1303 Part A – Data Structures and Algorithms

Serve an item:

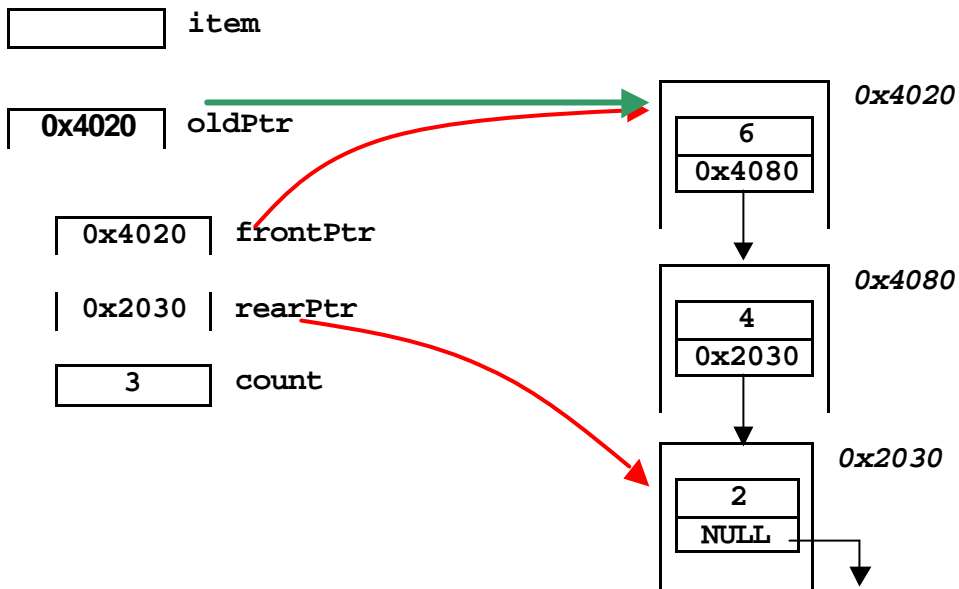

...

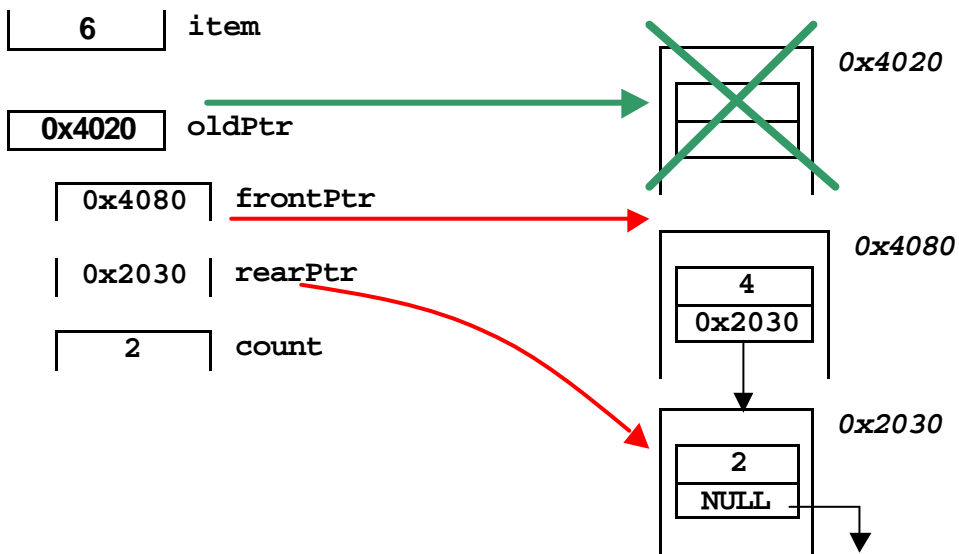

You need to read out the item, then move the `frontPtr` **before** freeing the old head node.

CSE1303 Part A – Data Structures and Algorithms

Note:

Serving an item which will empty the queue needs to be dealt with specially:

