

12 Hodgkin-Huxley Model

(based on chapter 12, W.W. Lytton, *Hodgkin-Huxley Model*)

12.1 Why learn this?

- In the 1950s Alan Hodgkin and Andrew Huxley worked out the ionic basis of the action potential and developed a mathematical model that successfully predicted the speed of spike propagation.
- Their work can be regarded in retrospect as the beginning of computational neuroscience.
- It remains the touchstone for much neural modeling today.
- The Hodgkin-Huxley model demonstrates how computer models can reveal biological properties that cannot be examined directly.
- Hodgkin and Huxley described two ion channels.
- Since then hundreds have been described and some of the basic parameterization has been updated.
- Despite this, the modeling techniques that Hodgkin and Huxley developed are still used and remain the standard model today.

12-1

12.2 From passive to active

- The simulations in Chap. 11 used a simple RC circuit.
This is a passive membrane model because the conductance remains constant.
In this chapter, we use the same passive components (the R and the C), and add active components as well.
- Active components are conductors that change their conductance in response to changes in membrane voltage or due to activation by a chemical.
- Voltage-sensitive channels are responsible for the action potential.
- Chemical-sensitive channels are responsible for synaptic activation in response to the arrival of a ligand at a synapse.
- In general, voltage or chemical-sensitive channels are considered active channels because they are activated in response to some signal.
- Channels that remain at a fixed conductance are called passive channels.

12-2

The resting membrane potential is about -70 mV

- The simulations in the previous chapter were simplified by starting at a resting potential of 0 mV.
- In real life, the membrane rests at a negative potential of about -70 mV (different cells differ).
- This is the resting membrane potential (RMP) of the cell.
- The resting potential is set up by pumps that separate charge across the membrane, producing various fixed potentials associated with different ions.
- This charge separation will be represented by batteries in the electrical circuit diagram.
- They are denoted the sodium battery, the potassium battery, etc.
- The polarity of the individual batteries depends both on the polarity of the ion involved and on the direction of the inside-outside concentration gradient for that ion.
- Each battery will only affect membrane voltage when the ion channels open for that particular ion.
- In the circuit diagram, this is represented by connecting each battery through a variable conductor.

12-3

The membrane is insulator, capacitor, and battery

- The addition of batteries and variable conductances to the circuit diagram demonstrates several other roles played by the cell membrane and by membrane proteins.
- As part of being an insulator and a capacitor, the membrane also allows the charge separation that sets up the batteries, each of which is associated with a different ion.
- Protein transporters pump the ions to charge each of these batteries.
- Active protein channels form the variable conductors (rheostats).
- These proteins will be sensitive to changes in membrane voltage or to chemicals or both.
- The resting (inactive) potential on the membrane is negative.
- Hence, both negative-going inhibitory signals and many positive-going excitatory signals will be negative relative to ground.

12-4

There is a standard nomenclature to describe voltage deviations from rest:

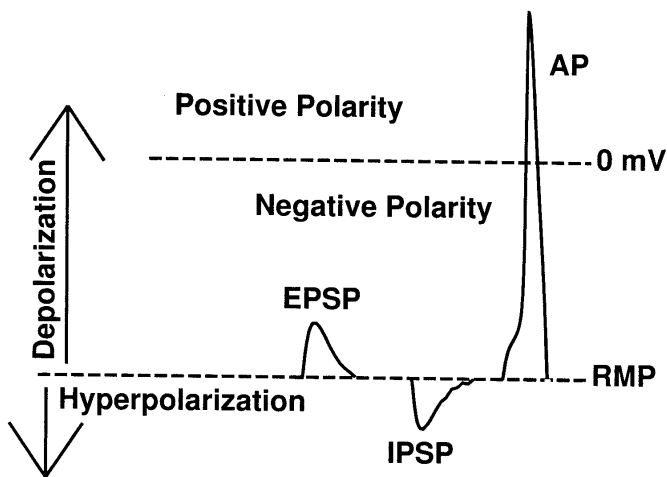
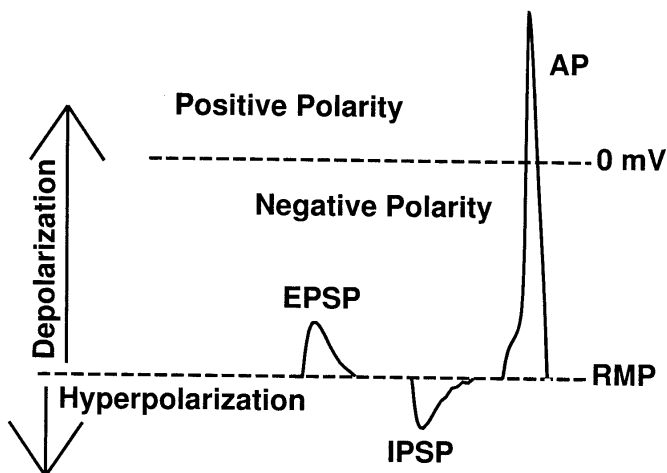

Fig. 12-1: Resting membrane potential (RMP) is typically about -70 mV (inside negative).

- Membrane can be depolarized as much as 120 mV or hyperpolarized as much as 30 mV from rest.
- Excitatory postsynaptic potentials (EPSPs) depolarize; many inhibitory postsynaptic potentials (IPSPs) hyperpolarize.
- Action potentials (APs) are depolarizations that can overshoot 0 mV, temporarily reversing membrane polarity.

- Negative deviations, which make the membrane even more negative than at rest, are called hyperpolarizing (hyper means more).
- Hyperpolarizing inputs are generally inhibitory.
- Positive deviations, which make the membrane less negative than it is at rest, reducing its polarization, are called depolarizing.
- Depolarizing signals move the membrane potential toward or past 0 mV.

12-5



- Depolarizing inputs are generally excitatory.
- Hyperpolarization and depolarization are not symmetrical.
- The membrane can be naturally depolarized by about 120 mV.
- 120 mV above rest is +50 mV relative to ground ($-70 + 120 = 50$), approximately the value of the sodium battery.

- Natural activity will only hyperpolarize the cell by about 20 to 30 mV. 20 to 30 mV below rest is about -90 to -100 mV relative to ground ($-70 - 30 = -100$).
- This is about the range of values for the potassium battery, which may differ somewhat among different cell types.
- Experimentally, one can hyperpolarize the membrane beyond -100 mV by injecting negative current through an electrode inside of the cell.
- Artificial depolarization with injected current is limited by the tendency of prolonged depolarization to kill the cell.

12-6

Synaptic inputs aren't current injections

- In the simulations in Chap. 11, I started by using square wave current injections as signals. These were similar to the current injections used by physiologists.
Then I moved on to the alpha function as a more natural signal. I was still using current injections.
- Most synapses in the nervous system are chemical synapses.
- The associated synaptic potentials, the natural input signals for neurons, generally arise as conductance changes rather than current injections. The current that flows is secondary to the conductance change.
- (There are also electrical synapses where current flows through a channel connecting two neurons.)

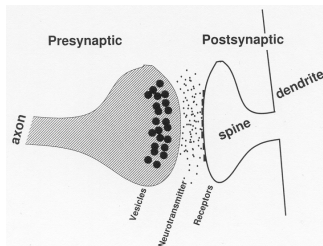

- A chemical ligand (neurotransmitter) is released presynaptically.
 - It floats across the synaptic cleft and binds to a receptor on the postsynaptic membrane.
 - This receptor is connected either directly or indirectly to one or more ion channels that conduct current across the membrane.
- Depending on which ions the channels allow through, the synaptic current can be inward (depolarizing) or outward (hyperpolarizing).
 - In our electric circuit diagrams, this will correspond to connecting up a particular battery by activating a switch or a controllable conductance (a rheostat).

12-7

12.3 History of the action potential

- The story of the action potential starts with Luigi Galvani's 1791 discovery that electrical signals from lightning or primitive batteries could cause contraction of the leg of an otherwise dead frog leg.
- This was an inspiration to mad scientists, and researchers started performing similar experiments on the heads of hanged criminals, attempting to bring back the dead with electricity at around the time that Frankenstein was written.
- The National Institutes of Health do not encourage this line of research nowadays.
- Perhaps these demonstrations had some value in that they suggested that mysterious human abilities such as motion, sensation, and thought could be caused by a physical process.
- On the other hand, connecting thought to electricity may not have been so disturbing at that time, since electricity was itself another mysterious process that could be readily equated with an unknowable "life force."
- A later finding that brought neural function further into the physical, non-ethereal realm was the demonstration of neural delays by Hermann Helmholtz, the famous 19th century scientist.
- Helmholtz showed that stimulation of a nerve at different points led to contractions of the corresponding muscle at measurably different times.
- Not only was the speed measurable, but it was relatively slow (about 70 mph).
- Helmholtz's father wrote him a letter rejecting these findings as absurd.

12-8

- Helmholtz's father was sure that he could directly perceive the world, and that his thoughts were converted directly into actions.
- If he moved his hand and watched it, perception didn't fall behind.
- Research into the seeming seamlessness of experience is now actively pursued using careful timing of perception and brain electrical activity.
- An understanding of how the illusion of simultaneity arises despite varying delays of sensory signal processing would provide a partial solution to the mind-body problem.

Hodgkin and Huxley

- By the time Hodgkin and Huxley got to the problem, much progress had been made. The resting potential was well described and the action potential had been described as a “negative variation” in this potential.
- (We now describe the action potential from the inside as a positive variation: positive inside, negative outside.)
- The squid axon had been picked out as an ideal experimental preparation due to its enormous size compared to other neurons.
- Squids, like other invertebrates, have unmyelinated axons — wires without insulation.
- Their axons are leaky and prone to signal loss, which has caused them to evolve extremely broad axons that conduct electricity better.

12-9

- From the experimentalist's point of view, this makes them big enough to see and to stick wires into.
- Hodgkin and Huxley threaded a fine silver wire inside the axon.
- With this, they could measure the electrical potential inside and deliver enough current so as to maintain a particular voltage despite the efforts of the ion channels in the membrane to change it.
- This is called voltage clamp.
- They measured how much current was required to keep the voltage from changing.
- This told them how much current was being passed through the axon membrane and in which direction.
- They could then figure out which ions were responsible for which currents by doing the same experiments in sodium-free or potassium-free solutions.
- By running these experiments at many different voltages, they found out how the sodium and potassium currents grew and shrank with changes in membrane potential.
- They used these data to construct the parallel-conductance model.

12-10

12.4 The parallel-conductance model

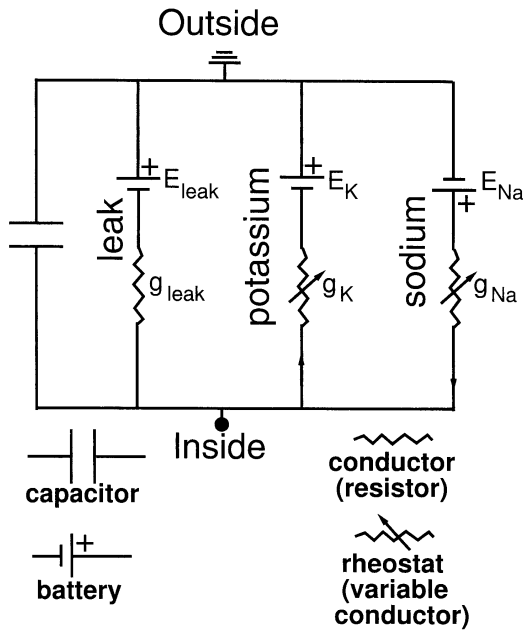
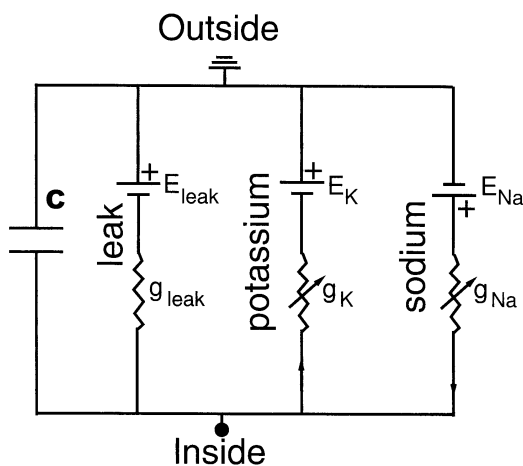

Fig. 12.2: Parallel-conductance model of the membrane. The various variable conductors (variable resistors, rheostats) connect the inside and outside. They are arrayed in parallel.

- The parallel-conductance model is similar to the basic RC model.
- Once again all points on the inside of the membrane are electrically connected via the cytoplasm (horizontal line at bottom).
- This is the point where we measure potential.
- The outside of the membrane is connected via the extracellular fluid (horizontal line at top) and is grounded, keeping it at 0 mV.

12-11



- The inside and outside of the membrane are connected via four parallel conducting pathways. On the left side are the membrane capacitor and the fixed membrane conductance.
- These two passive components are similar to those of the simple RC model.
- However, the resistor in this case is connected to a battery.
- Batteries are represented by two parallel lines of different lengths. The long line of the battery schematic indicates the positive pole.

- The passive conductance in the parallel-conductance model is known as the leak conductance.
- Because the channels carrying this current are not voltage-sensitive, the leak conductance remains the same at any voltage, providing a constant “leakiness” for current.
- The potential of the battery associated with g_{leak} is E_{leak} (E for electrical potential and V for voltage are synonymous but E is usually used for batteries.)
- The short line of the leak battery is connected to the inside of the membrane making the membrane inside-negative.

12-12

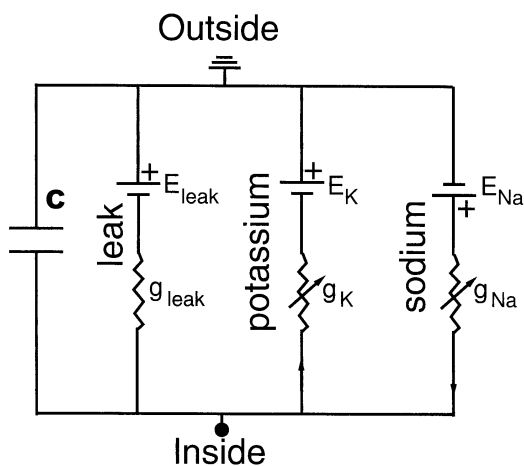

- E_{leak} is the major determinant of resting membrane potential.
- On the right side of the circuit diagram are the two active branches: the sodium battery and conductance, and the potassium battery and conductance.
- Note that these two batteries are pointed in opposite directions.
- The potassium battery, like the leak battery, will make the membrane negative.
- The sodium battery will make the membrane positive.

- The conductance symbol under each battery has an arrow through it.
- This means that it is a variable (or controllable) conductor, also called a rheostat.
- The rheostat is the thing you turn to dim the room lights to set a romantic mood.
- In this case, the rheostats will be controlled not by the level of romance but by the level of the membrane voltage.
- Since the rheostat influences membrane voltage and the membrane voltage influences the rheostat, this will lead to positive or negative feedback loops, as will be described below.

12-13

- At rest, the sodium and potassium conductances are turned off so that these two lines are not conducting.
- Under these circumstances, the two associated batteries have no effect on membrane voltage.
- If one of these conductors were to be turned all the way on (zero resistance), then the associated battery would dominate the membrane potential.
- If both of these conductors were turned on all the way at the same time, you would have the situation that you get when you connect the leads wrong while jumping a car battery — the battery will discharge massively, overheat, and blow up.
- Luckily, this doesn't happen in the brain.

Currents

- Benjamin Franklin defined current as the flow of positive charge. In electronic equipment, current through wires is carried by negative electrons.
- Therefore, the direction of current in wires is opposite to the direction that charge flows.
- In biology, current is carried by ions from dissolved salts that move through water.
- Most of the ions involved are positive, like sodium (Na^+), potassium (K^+), and calcium (Ca^{++}). Chloride (Cl^-), a negative ion, is also important.

12-14

- Positive ions, with one or more superscript +, are called cations; negative ions, with superscript −, are called anions.
- Because calcium has twice the charge of sodium, movement of calcium ions will result in twice as much current.
- When dealing with cation flux, the direction of ion movement is the same as the direction of current.
- Current is measured during voltage-clamp.
- To clamp a constant voltage onto the membrane, current is injected or withdrawn from the inside of the cell through an electrode.
- This current must exactly cancel out any currents that are passing through the membrane in order to prevent these membrane currents from changing the membrane potential.
- Current direction is defined with respect to the membrane, not the electrode.
- Inward current is positive charge going across the membrane from outside to inside.
- Outward current is positive charge going from the inside of the membrane to the outside.
- Interpreting voltage-clamp results is a bit of an art.
- Sodium (positive ions) passing into a cell or chloride (negative ions) passing out of a cell would both be examples of inward current.
- Since sodium is at a higher concentration outside of the cell, an increase in sodium flux will result in an inward current.

12–15

- Potassium, being at higher concentration inside the cell, would be a typical outward current.
- When the membrane is stable (whether at RMP or at some other voltage imposed by voltage clamp), there is some balance of ongoing outward and inward currents.
- In addition to an increase in these baseline currents, it is possible for an experimental manipulation (a drug or a voltage step) to produce a decrease in the baseline currents.
- An increase in potassium current is an outward current, but a reduction in the baseline potassium current is measured as an inward current.
- Chloride reversal potential is near to RMP.
- Therefore, a chloride flux can be either inward or outward.
- Because chloride carries a charge of -1 , a decrease in inward chloride flux is an inward current.

12–16

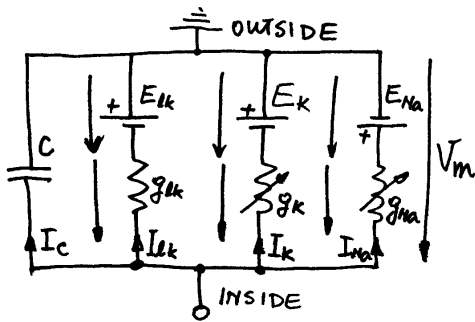

- The calculations for the parallel-conductance model are similar to those for the RC model except that we have to add in the batteries.
- E_{lk} is the value of the leak current battery, usually about -75 mV.
- The membrane voltage, V_m , is the same for each parallel branch of the circuit. Hence we can write:

- For the Sodium branch: $V_m = E_{Na} + \frac{I_{Na}}{g_{Na}}$. Hence the current: $I_{Na} = g_{Na} \cdot (V_m - E_{Na})$

- For the Potassium branch: $V_m = E_K + \frac{I_K}{g_K}$. Hence the current: $I_K = g_K \cdot (V_m - E_K)$

- For the leak branch: $V_m = E_{lk} + \frac{I_{lk}}{g_{lk}}$. Hence the current: $I_{lk} = g_{lk} \cdot (V_m - E_{lk})$

- The current through the capacitor is proportional to the time derivative of the voltage across

$$I_C = C \cdot \frac{dV_m}{dt}$$

- With no external current injected the sum of all currents is zero (Kirchhoff's law)

$$I_C + I_{lk} + I_K + I_{Na} = 0$$

- Substituting the currents gives the parallel-conductance equation:

$$C \cdot \frac{dV_m}{dt} + g_{lk} \cdot (V_m - E_{lk}) + g_K \cdot (V_m - E_K) + g_{Na} \cdot (V_m - E_{Na}) = 0$$

12-17

- Positive capacitive current, I_C is a depolarizing current that that makes the inside of the membrane more positive.
- In the parallel-conductance equation, as in the RC model, capacitive current is opposite in sign from the conductive currents.
- Therefore, a negative conductive current is a positive capacitive current and produces depolarization.
- Negative conductive currents are inward currents, involving the flow of current through ion channels from outside to inside.
- Notice that negative current has nothing to do with the sign of the ion that is carrying the current.
- Instead, it is an indication of the direction of current.
- Also notice that the sign change is confusing: a negative membrane current produces a positive voltage effect.
- The direction of negative current is an arithmetic consequence of measuring membrane voltage on the inside rather than the outside.
- In the literature, the phrase “membrane current” is used as a synonym for conductive current.
- Therefore, negative current flows in and depolarizes; positive current flows out and hyperpolarizes.
- However, it's worth remembering that there is zero total current flow: the inward conductive current is matched by outward capacitive current.
- It is actually the latter that is most closely associated with the depolarization.

12-18

- At **steady state**, there will be no capacitive current $I_C = 0$ since voltage is not changing and its time derivative is zero.

- Summing non-zero currents we get:

$$g_{Na} \cdot (V_m - E_{Na}) + g_K \cdot (V_m - E_K) + g_{lk} \cdot (V_m - E_{lk}) = 0$$

- Solving this equation for V_m gives the resting membrane potential:

$$V_m = \frac{g_{lk} \cdot E_{lk} + g_{Na} \cdot E_{Na} + g_K \cdot E_K}{g_{lk} + g_{Na} + g_K}$$

- This is a version of the Goldman-Hodgkin-Katz (GHK) equation.
- It says that steady-state membrane voltage is the weighted sum of the batteries, with the weighting provided by the conductance associated with that battery.
- Since g_{lk} is the dominant conductance at rest, it will have the greatest effect on determining RMP.
- If a conductance is turned off completely (e.g., $g_{Na} = 0$), the corresponding battery has no influence.
- If, on the other hand, a conductance is very high, then the other batteries will have very little influence, e.g.,
- if $g_{Na} \gg g_K$ and $g_{Na} \gg g_{lk}$, then $V_m \approx \frac{g_{Na} \cdot E_{Na}}{g_{Na}} = E_{Na}$

12-19

Where do the batteries come from?

- The batteries are an indirect result of proteins that pump ions across the membrane.
- These ions then try to flow back “downhill,” in the direction of their chemical gradient from high concentration to low concentration.
- Only a little current has to flow in order to set up an equal and opposite electrical gradient.
- The electrical gradient, opposite in direction to the chemical gradient, is the battery.
- This electrical potential is called the Nernst potential.
- It can be precisely calculated by knowing the concentrations of a particular ion inside and outside of the cell (see Glossary for definition).
- Each ion has its own Nernst potential.
- The value in millivolts of the Nernst potential is the strength of the battery that we use in the circuit diagram.
- With its many ins and outs, the origin of the Nernst potential can be confusing.

12-20

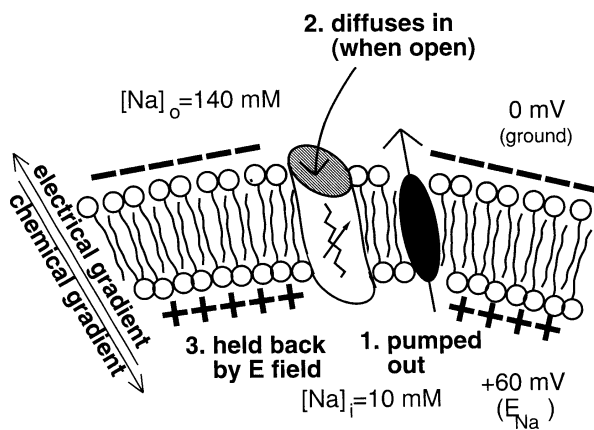
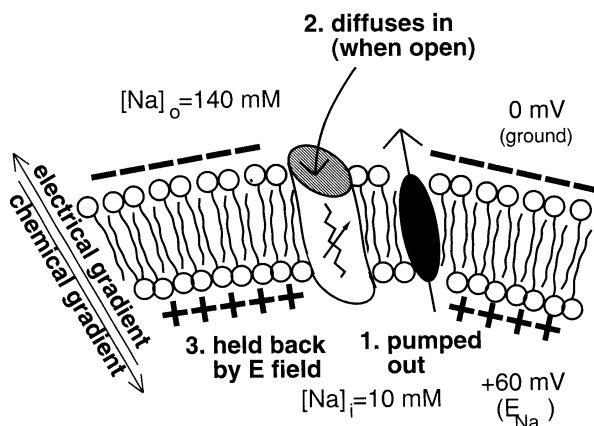

Fig. 12.3:

The origin of the Nernst potential for example of Na^+ . Na^+ is pumped out by an energy-consuming protein, flows back in through Na^+ channels, and is pushed back as it creates its own electric field. The sodium flux eventually reaches electrochemical equilibrium at a potential of about 60 mV. The superimposed rheostat sign is meant to indicate that the channel can be open or closed.

- Sodium is pumped from inside to outside (#1 in Fig. 12.3) by a protein that uses energy from ATP (adenosine triphosphate).
- The pumping leaves sodium concentration outside of the cell ($[\text{Na}]_o \approx 140$ millimoles) higher than it is in the cytoplasm ($[\text{Na}]_i \approx 10$ millimoles).
- The concentration difference across the membrane does not in itself lead to any charge separation, since sodium ions on both sides are appropriately matched with negatively charged proteins.
- Since there is more sodium outside, it “wants” to flow inside due to diffusion (#2 in Fig. 12.3).
- (Diffusion is what makes a drop of ink spread out in a glass of water; it wants to go where no ink has gone before.)

12–21



- As long as the selective channels for sodium remain closed, sodium cannot diffuse and the sodium concentration gradient has no effect on membrane potential.
- When the sodium channel opens, sodium rushes down its concentration gradient.
- The negative proteins that are paired with the sodium ions cannot follow; they are not allowed through the sodium channel.

- This diffusion of sodium across the membrane leads to charge separation across the membrane, with unmatched sodium ions on the inside and unmatched negative protein molecules on the outside.
- The unmatched sodium ions inside the membrane will stay near the membrane, in order to be close to their lost brethren.
- This bunching of positives next to the inside of the membrane, with a corresponding bunching of negatives next to the outside, creates an electric field (#3 in Fig. 12.3) that opposes inward diffusion through the ion channels.
- This outward electric field is the sodium battery.

12–22

- The inward diffusive force and the outward electrical force reach a steady state (Nernst equilibrium) so that there is no net flow of ions and little need for continued pumping to maintain equilibrium.
- The concentration difference between inside and outside can be directly translated into an electrical potential by using the Nernst equation.
- E_{Na} is approximately +60 mV.

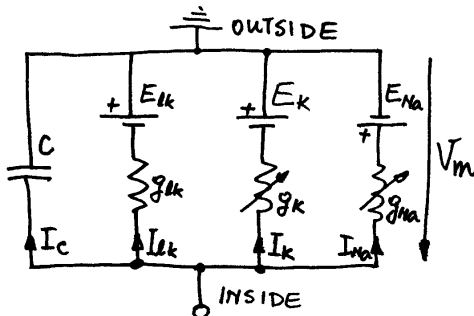

- The positive plate of the sodium battery is 60 mV relative to the negative plate.
 - By contrast, potassium is at high concentration inside and low concentration outside.
 - The potassium chemical gradient is outward so the electrical gradient is inward.
- The positive inward electrical gradient would be +90 mV if measured from the outside of the membrane, relative to a grounded inside.
 - However, we always measure the potential on the inside, relative to ground outside, so the potassium potential (E_K) is about -90 mV.

12-23

- All of the reversal potentials can vary slightly in different cells (different pumps) or under different conditions.
- For example, the sodium reversal potential can be slightly lower if you're sweating a lot: less sodium outside, less inward chemical gradient, less outward electrical gradient.
- The potassium reversal potential gets less negative under conditions where cells fire a lot.
- The constant firing allows potassium to build up outside of the cells.
- The accumulation of extracellular potassium reduces the outward chemical gradient, reducing the inward electrical gradient.
- Because resting membrane potential is largely determined by baseline potassium flux (the leak conductances conduct primarily potassium), this change in E_K changes E_{Ik} and depolarizes cells.
- Even cells that have not themselves been firing are affected.
- In this way, extreme activity in one set of cells can depolarize neighboring cells and make them more excitable.
- This is one factor that can lead to the spread of uncontrolled activity in seizures.

12-24

12.5 Behavior of the active channels

- To complete the Hodgkin-Huxley model, we have to describe the behavior of the sodium and potassium channels.
- We continue to look at the model from several different descriptive perspectives.
- First, we presented the electronics perspective and considered the channels as rheostats.
- Second, we talked about ion channels from a biophysical viewpoint, describing flux and electrochemical equilibrium.
- Third, we will describe the interaction of the channels in terms of positive and negative feedback systems.
- Fourth, we will return to ion channel behavior, describing their conductance properties in terms of somewhat mythical “particles.”
- Fifth, we will study the equations that model the system.
- Sixth, we will run the simulation and demonstrate the model graphically.
- This mess of descriptions includes different levels of organization (single channel vs. whole membrane), different approaches (electrical engineering vs. biology), and different methods of presentation (numerical vs. graphical).
- Doing modeling from so many directions would seem to make things harder rather than easier.

12–25

- It means that we have to not only understand concepts in biochemistry, biology, and electronics, but also be familiar with various tools provided by math and computer science.
- Additionally, we will see that not all of the descriptions are fully consistent with one another.
- For example, electronically we described the sodium channel as a rheostat.
- However, we also describe the sodium channel as having little on and off switches, making the channel sound more like a tiny sub-circuit than like a rheostat.
- The payoff for all of this hard work can be appreciated by considering the famous parable of the blind men who meet an elephant (one feels the trunk, one a leg, another a tusk, etc., and they give widely discrepant descriptions of the beast).
- None of them knows anything useful about elephants but, if they pool their knowledge, they may be able to create a passable picture.
- Similarly, coming at a model from many angles permits us to come closer and closer to understanding the thing itself.
- We have neither the concepts nor the mental capacity to allow us to wrap our brains around all of this complexity, and see nature as it really is.
- Instead we use these different models as tools to pick up different clues to this underlying reality.
- As we move back and forth between representations, we gain further insights.

12–26

- There are other approaches to describing the Hodgkin and Huxley model, in addition to five or six that I use in this chapter.
- For example, one can use complex graphical representations that allow us to look at several dimensions of the dynamics at once.
- This is called a phase-plane representation.
- There are also other kinds of mathematical tricks that can help us understand the system better.
- An example of this would be descriptions of nullclines and of the space of solutions as a field.
- Going beyond the scope of the Hodgkin and Huxley model, we could look at levels of detail that are not directly considered in the model: we could describe the detailed molecular conformation changes that determine channel opening and closing or include the detailed physical chemistry of how salts and water interact.

12–27

Feedback systems

- The Hodgkin and Huxley sodium and potassium channels are voltage-sensitive conductances.
- They go on and off with voltage change.
- As we describe the cycle of the action potential, we can speak in terms of positive feedback and negative feedback.
- Positive feedback occurs when the cycle of influence causes a change to produce more change in the same direction.
- If, for example, the faster you drive the more excited you get about driving fast (a positive feedback loop), you will tend to drive faster and faster.
- Positive feedback systems are not self-limiting; they are limited by something outside of the positive feedback system (i.e., a crash) or the opposition of some negative feedback system (e.g., prudence or the police).
- Negative feedback systems are self-limiting, since the cycle of influence produces a change that opposes the original change.
- Negative feedback is very common in biological systems: hunger makes you eat, food reduces hunger.
- The Hodgkin and Huxley model uses two types of ion channels that are controlled by three types of switches.

12–28

- Turning on the sodium channel pushes voltage up (depolarizes) and turning on the potassium channel pulls it back down (hyperpolarizes).
- The channels are controlled by voltage.
- The sodium channel is controlled by both on and off switches. Increasing voltage turns on the sodium channel.
- This is a positive feedback loop.
- Increasing voltage also turns off the sodium channel, by means of a different switch.
- This is a negative feedback loop.
- The potassium channel only has one type of switch.
- Increasing voltage turns on the potassium channel, hyperpolarizing the membrane and providing a negative feedback loop.

12-29

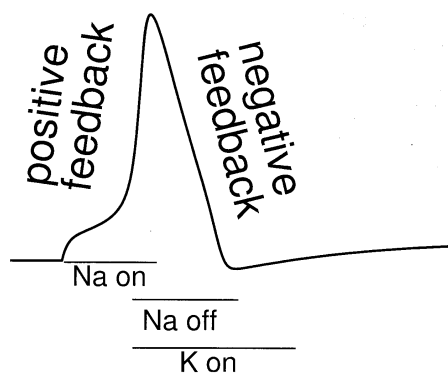

Fig. 12.4: Positive and negative feedback shape the action potential.

- The positive and negative feedback loops happen at different rates in the Hodgkin-Huxley model (Fig. 12.4).
 - Initially, the action potential is triggered by a depolarization (movement of the potential in a positive direction, toward 0 mV).
 - This can be a result of a current injection or a synaptic potential.
 - This depolarization causes the sodium channel to switch on quickly.
- Current through the sodium channel will cause more depolarization, which will turn on the sodium channel more, which will cause more depolarization, which will turn on the sodium channel more ...
 - This is the positive feedback that produces the upswing of the spike as voltage rises rapidly.
 - The sodium channel's on-switch provides the positive feedback by activating the channel with depolarization.
 - The off-switch provides the negative feedback by inactivating the channel during depolarization.
 - While the sodium channel is being switched on, it is being more slowly switched off.
 - The delay in negative feedback allows potential to rise about 100 mV over about a millisecond.

12-30

- Then negative feedback kicks in. The action potential reaches its peak as the sodium channel switches off and the potential heads back down toward resting potential.
- Further negative feedback is provided by the turning on of the potassium conductance.
- This connects the membrane to the negative potassium battery, which opposes the positive sodium battery.

12–31

Particle duality

- Hodgkin and Huxley emphasized that their model was empirical, meaning that they matched the behavior of the action potential without needing to know what exactly was going on at the molecular level.
- They had no reason to expect that the details would correspond to what actually exists in the membrane.
- However, the model did provide a set of successful predictions at the membrane level.
- Most notably, the model predicted the existence of ion channels turning on and off independently.
- There was no way to demonstrate these ion channels until patch clamping was developed decades later.
- Hodgkin and Huxley also had an implicit view of the functionality of switches controlling the ion channels.
- They called these switches particles.
- At the single-channel level, each particle was binary, taking on a value of 0 for blocking and 1 for nonblocking.
- The implicit concept portrayed the particles as physical objects that could block a single channel and prevent flow of current.
- Both the sodium and the potassium channel were described as having four particles.

12–32

- In the case of the potassium channel, each of the four particles behaves identically.
- Each of these potassium particles is called n .
- Mathematically, the presence of four particles per channel is denoted by a multiplication:
 $n \cdot n \cdot n \cdot n = n^4$.
- In the case of the sodium channel there are $3m$ particles and one h particle, giving $m^3 \cdot h$.
- When considering the single-channel level, each particle is binary-valued.
- However, at the population level, each particle takes on analog values between 0 and 1.
- This binary-analog particle duality is the kind of anomaly that can crop up as we move from one view of a model to another.
- Looked at from the bottom-up view, the particles appeared as little independent objects that could either block the channel and prevent conduction or get out of the way and allow conduction.
- If any particle is blocking a channel, that channel is closed and there is no flow through it.
- This view of the model gives the binary values: 1 for not blocking and 0 for blocking.
- Looking at the model from a higher level (perhaps not high enough to be top-down, maybe middle-sideways), the particles in the Hodgkin-Huxley model represent a population and are represented by analog values.
- At the single-channel level, a channel is either opened or closed, 1 or 0.

12–33

- When we consider a large population of channels, some percent of this population will be open and the rest closed.
- We use an analog value from 0 to 1 to denote the percent of channels that are open.
- Similarly, particles take on a binary value, blocking or not blocking, when considered at the single-channel level but an analog value when considering the entire channel population.
- This analog value for the particle represents an unblocking probability or, equivalently, the percent of particles that are not blocking at a given time.
- Hence, to model a population of channels, we end up modeling a “population” of m particles, a “population” of h particles, and a “population” of n particles.
- This doesn’t really make much sense because an m particle belongs to a channel.
- There is physically a population of channels, but not an isolable population of m particles.
- This binary-analog particle duality is an example of a common problem in modeling.
- An aspect of a model that makes literal sense at one level is manipulated for computational or organizational convenience at another level.
- Or, as in this case, an aspect of a model that was arrived at empirically reveals interesting predictions when its detailed implications are looked at.
- Either way, the back and forth between levels alternately obscures and illuminates.

12–34

- In the present case, binary particles are conceptually helpful at the single-channel level, making predictions about what may be going on in individual channel molecules.
- Although the prediction of a physical blocker has not been borne out for the particular channels that Hodgkin and Huxley studied, other potassium channels have been described in which a piece of a protein physically occludes the channel.
- At the membrane level, individually modeling a vast population of individual channels with individual particles was hopeless in Hodgkin and Huxley's day.
- It is computationally feasible nowadays but would not be practical for large simulations.
- The m population makes little sense at the channel level but describes the action potential extremely well.

Thus, this compromise is both useful and used.

12–35

Particle dynamics

- The population of m particle moves gradually from near 0 toward 1 during depolarization. This turns the sodium channel on.
- At the same time as the sodium channel is being turned on through the movement of the m particle from 0 to 1, it is also starting to turn off through the movement of the h particle from 1 to 0. h changes more slowly than m .
- Eventually h approaches 0 and sodium channel conductance drops to a small value.
- The n particle goes from 0 to 1 at about the same rate at which h goes from 1 to 0.
- This increases the potassium conductance, giving the potassium battery more influence over the circuit. The potassium current opposes and eventually reverses the spike depolarization.
- m moves quickly to unblock the sodium channel, while h moves slowly to block it and n moves slowly to unblock the potassium channel. Since m moves so much faster than anyone else, sodium channel unblocking dominates at the beginning.
- m increases, unblocking the channel and providing the positive feedback.
- At the same time, the slower n movement is leading to some unblocking of the potassium channels, increasing potassium current and reducing this depolarization through negative feedback.
- During the action potential downswing, everything reverses. m heads toward 0. n heads toward 0 more slowly. h goes back toward 1.

12–36

12.6 The particle equations

- Now let's look at the equations that describe m , h , and n .

I show the underlying functions graphically here; the full set of functions is given under "Hodgkin-Huxley equations" in the Glossary.

Conveniently, the same basic form is used for all of the particles.

- The value of the sodium and potassium conductances are products of a maximal conductance value and the values of their associated particles.

$$\text{sodium: } g_{Na} = \bar{g}_{Na} \cdot m^3 \cdot h \quad , \quad \text{potassium: } g_K = \bar{g}_K \cdot n^4$$

Conductance is represented by g and maximum conductance by \bar{g} , which is called either "g-bar" or "g-max."

- If all the particles were set to 0, then $g_{Na} = g_K = 0$ and we would be left with only the passive membrane.
- If all the n particles were set to 1, then potassium current would be maximal: $g_K = \bar{g}_K$
- If all the m particles were set to 1, but the h particle was 0, then g_{Na} would still equal 0.
- As we will now see, the parameterizations for these particles involve asymptotes that do not allow them to ever reach 0 or 1, but they can get close.
- Each particle is indirectly parameterized by voltage.

12-37

- At the negative resting membrane potential, the m particle of the sodium channel is near 0 (off) and the h particle is near 1 (on).
- During the action potential m will go from 0 toward 1 and h will go from 1 toward 0. m will change faster than h will.
- We are dealing with rates of change, so once again we use calculus and differential equations to describe the process.
- The differential equation for m

$$\tau_m \cdot \frac{dm}{dt} = m_\infty - m$$

It is a standard form for a first-order differential equation. m will approach m_∞ at the steady-state when derivative approaches zero after an infinite amount of time.

- Similarly as in the RC charging curve, the time constant τ_m determines how fast m will approach m_∞ . As with the charging curve, the solution to the differential equation for m will be an exponential.
- However, in contrast with the fixed parameters of the passive membrane equation, the parameters of the particle equations are not constant.
- They are functions of voltage (Fig. 12.5) and the voltage keeps changing.

12-38

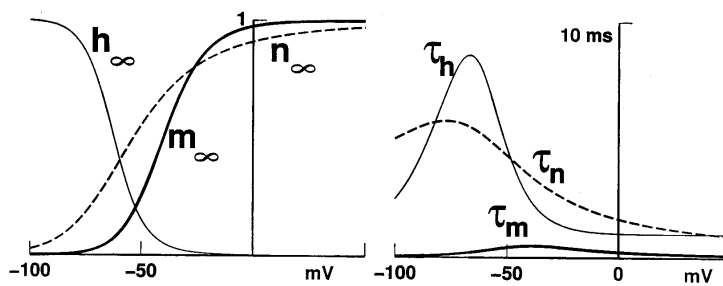

Fig. 12.5:

Control parameters m_∞ , h_∞ , n_∞ , τ_m , τ_h , τ_n are themselves parameterized by voltage. (τ values are given at a squidish 6.3°C .)

- Let's take m as an example. Since voltage is changing, m is chasing a moving target, m_∞ .
If the membrane is being depolarized, m_∞ is getting bigger and m is moving toward a bigger number.
- τ_m is also changing with voltage, speeding up or slowing down the rate at which m is moving toward m_∞ .
 τ_m triples with the first 30 mV of depolarization from rest, slowing down the rise of m and thereby providing another, relatively minor, negative feedback.
- The equations for h and n are described by equations of the same form.
 m , n and h are all simultaneously following their own moving targets at their own changing rates.
- The time constant curves show that τ_m is much smaller than τ_n or τ_h at all voltage levels.
This means that m will always move faster than h or n .
- Specifically, τ_m is less than a half millisecond at all voltages.

12-39

This allows m to follow m_∞ with a time lag of about a millisecond (two to three time constants).

- τ_n and τ_h are in the range of 2 to 10 ms.
Grossly, these particles will lag behind their infinity values by about 10 to 20 ms.
- The rates for all of these processes, like other chemical reactions, are dependent on temperature.
- Action potentials at ocean temperature (e.g., in a cold-blooded squid) take place much slower than they do in a warm squid or a warm person.
The τ 's all have to be adjusted to take account of temperature.
The adjustment factor for channels and for other active proteins is called Q_{10} (pronounced "q-ten").

12-40

State variables define a state

- Having introduced all the components, it is apparent that this is a highly complex system of interacting parts.
There are four differential equations, one each for V , m , h , and n .
 V , m , h , and n are the four state variables of the system.
- We previously discussed the concept of state in the context of neural activity and neural representation. In the case of linked differential equations, one defines the state of a dynamical system by noting the values of all of the state variables.
- The Hodgkin-Huxley system is a four-dimensional system.
The state at any time can be given as a point in four-dimensional space.
- The differential equations are not independent. They interact.
Something that happens to one state variable will eventually affect all of them.
- Depending on the equations, the time constants, the feedback loops, interactions with other bodies, etc., this effect may become apparent in several weeks or only after many millennia.
Interlocking or linked differential equations are hard to grasp.
- All of these feedback systems can make it impossible to figure out who is doing what to whom when.
The behavior of each state variable is influenced by its history and by the history of the other state variables.

12-41

- When state variable A changes, it influences state variables B , C
These changes then feed back and change element A in turn.
- Chasing these state variable interactions around multiple feedback cycles produces proverbial chicken-and-egg predicaments.
- On the bright side, as linked ODEs go (ODE = ordinary differential equation), the Hodgkin and Huxley ODEs aren't so bad.
Everything is linked through only one state variable, voltage.
- This means that we can sometimes view events as if voltage were "controlling" everything, even though voltage is itself controlled by the current through the sodium and potassium channels.
- Taken in these terms, the genesis of the action potential can be viewed as the story of four state variables, each chasing its steady-state values.
- As an example, we can start with a current injection, I_{in} .
- V will start to chase $V_{max} = I_{in}/g_{memb}$
- As V rises, m_{∞} rises and m will chase m_{∞} with a slight delay.
- m rising causes rising g_{Na} causes rising I_{Na} .
- The additional current and conductance will push $V_{max} = I_{total}/g_{total}$.
- Notice that the increase in sodium conductance is actually opposing the increase in sodium current, another minor negative feedback.

12-42

- Meanwhile h is chasing h_∞ toward smaller-and-smaller numbers.
- This is slowly turning off the sodium channel even as the m particle is turning it on.
- Additionally, n is chasing n_∞ and turning on the potassium channel, pulling the potential down toward the negative value of the potassium battery.

12-43

12.7 Simulation

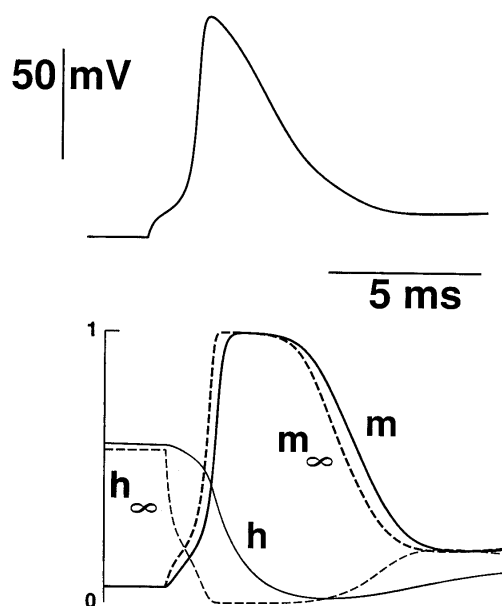
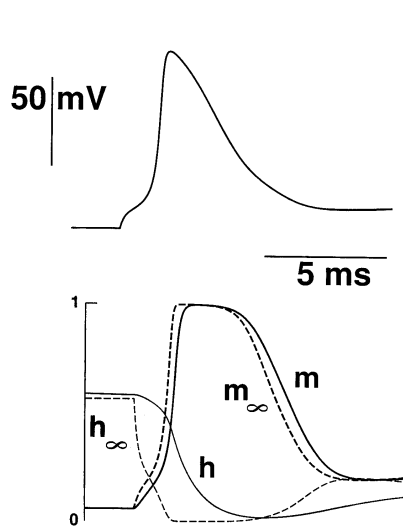

Fig. 12.6: Simplification of Hodgkin-Huxley model, without potassium channel.

- Without n , we are dealing with a three-dimensional system that would allow us to map the state in our regular three-dimensional space if we wanted to.
 - Instead, I use two-dimensional plots to map each state variable against time.
 - Fig. 12.6 also shows the steady state values m_∞ and h_∞ as they change with time.
 - Note that m follows m_∞ with a lag of about 1 ms, while h follows h_∞ with a longer lag.
 - At the end of the simulation m has caught up with m_∞ .
 - h still lags h_∞ since τ_h is considerably greater at this V value.
- The peak of the τ_h curve, about 8.6 ms at 6.3°C , is at -67 mV , which places it near resting membrane potential.
 - Therefore, the relaxation of h to h_∞ is relatively slow at this voltage.

12-44



Simplified model without potassium channel.

- The vocabulary for describing changes in active channels employs a set of confusingly similar words.
- Using V as a control variable that turns the other state variables on or off, we can construct the following table of descriptors for sodium channel control:

	$\uparrow V$	$\downarrow V$
m	activation ($\uparrow m$)	deactivation ($\downarrow m$)
h	inactivation ($\downarrow h$)	deinactivation ($\uparrow h$)

- Activation (of m) and deactivation (of h , note the double negative) are both needed in order to open the channel.
- Activation (of m) and deactivation (of h , note the double negative) are both needed in order to open the channel. Activation occurs with depolarization, and deinactivation occurs with repolarization. Without deinactivation, a second spike cannot occur.
- Similarly, either deactivation (of m) or inactivation (of h) can close the channel.

Inactivation terminates the sodium influx near the peak of the action potential, while deactivation is simply the resetting of m during repolarization.

We can say that: During the upswing m activates and h inactivates. During the downswing, m deactivates and h deinactivates.

Fig. 12.7:

The full Hodgkin and Huxley simulation showing all state variables.

Arrows indicate after hyperpolarization (AHP) and its cause.

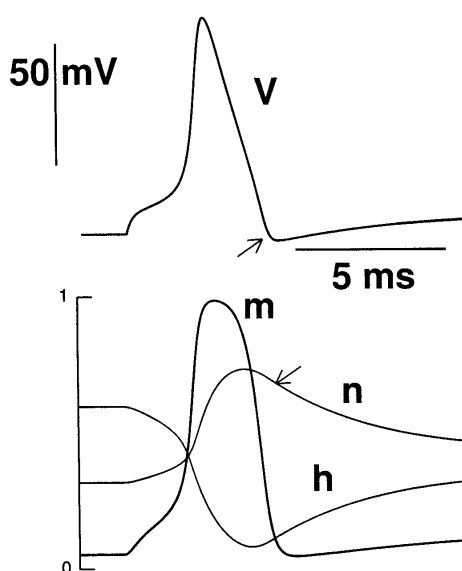

- Putting the potassium channel back into the model, the behavior changes slightly.
- Activation of the potassium channel turns on an outward current that helps pull the voltage back down toward rest after the peak of the spike (repolarization).
- The lag of n behind n_{∞} causes the potassium current to remain on a little longer so that the voltage overshoots the resting potential, producing an afterhyperpolarization (AHP, arrow in Fig. 12.7) as the potassium channel slowly deactivates (arrow on n).
- (Note that the potassium channel shows deactivation but no inactivation — there is an activation particle n but no inactivation particle.)

12.8 Implications for signaling

- The genesis of the action potential gives it several important properties that have implications for data transmission.
- These can be illustrated using the Hodgkin and Huxley model.
- These properties of neuron signal generation can provide bottom-up clues for constructing network models.

12-47

The threshold and channel memory

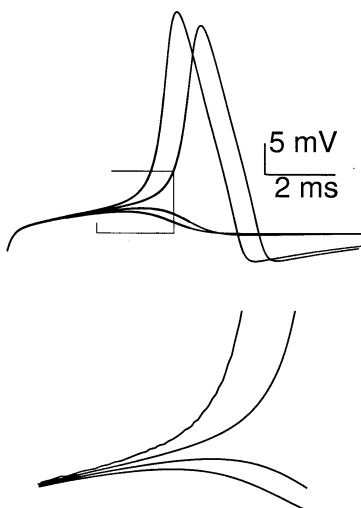

Fig. 12.8: Identifying the spiking threshold for a Hodgkin-Huxley model. The area around threshold is expanded below (rectangle).

- The action potential has a threshold. A current injection that does not reach the threshold does not generate a spike.
 - At the threshold, inward (sodium) current exceeds outward (potassium) current and positive feedback kicks in.
 - In Fig. 12.8, the threshold for firing is about -51 mV.
 - From the perspective of neural network theory, this threshold could be taken to be the sharp threshold of a binary activation function.
 - This would allow the neuron to add up its inputs and then provide a rapid signal indicating whether or not sufficient excitation had been received.
- However, in contrast to standard neural network theory, the Hodgkin and Huxley threshold is not a fixed value.
 - The three channel particles, m , h , and n , all respond with a lag. This lag provides a simple form of memory.
 - Something that happened in the past can be “remembered,” while the m , h , or n state variables catch

12-48

up with their steady-state values.

- The afterhyperpolarization (Fig. 12.7) is an example of this.
- The AHP reflects firing history — it's only present after the neuron has fired.
- This history is not always immediately reflected in the membrane potential but can be held hidden in the state variables, inaccessible to experimental detection.
- For example, a hyperpolarizing input provides immediate inhibition.
- The hyperpolarization opposes any depolarization that would push the potential up to threshold.
- However, after the hyperpolarization ends, h is left at a relatively high and n at a relatively low value for a brief period of time.
- This pushes the effective threshold down closer to rest, making it easier to fire the cell.
- A subsequent depolarization will open the sodium channel more, and the potassium channel less, than it otherwise would (Fig. 12.9).

12-49

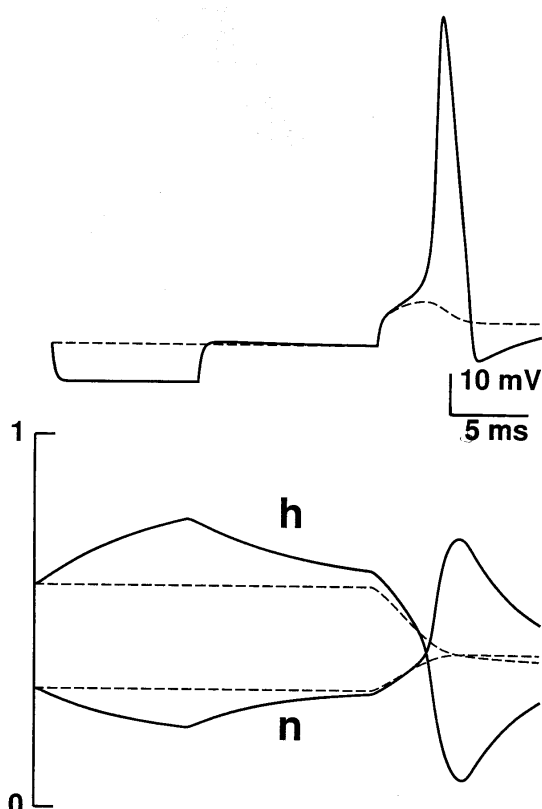

Fig. 12-9: With preceding hyperpolarization (solid line), h is elevated and n is depressed allowing a small depolarization to fire the cell 10 ms later. In the absence of the hyperpolarization, the same small stimulus is subthreshold (dashed line).

- Similarly, a preceding depolarization, which is immediately excitatory, will have a late effect that is inhibitory.
- From a neural network perspective, this membrane memory could be tuned to allow the neuron to respond preferentially to certain sequences of inputs.
- In this simple case, an optimal stimulation would involve an IPSP followed by an EPSP after an interval of two to three times τ_n at RMP.
- A neuron has dozens of channel types, allowing the construction of more complex responses that can build up over relatively long periods of time.
- A novel firing pattern could be the result of some combination of inputs occurring over several seconds.
- This would allow the use of very complex, hard-to-interpret coding schemes.

12-50

Rate coding redux

- Having speculated about complex history-dependent coding schemes, I now wish to return to the comforting simplicity of rate coding.
- In Fig. 11.13 we showed that slow potential theory explains the transduction from a presynaptic rate code to a postsynaptic depolarization plateau;
- increasing input rate gave an increased depolarization, due to increasing current flow.
- Using the Hodgkin-Huxley model, we can complete the sequence of signal transductions by showing that a depolarizing current injection converts to increasing firing rate within a certain range (Fig. 12.10).

12-51

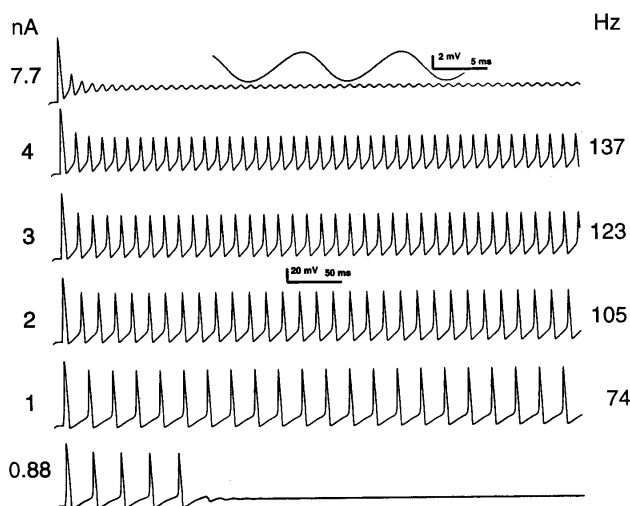

Fig. 12.10: Increasing firing frequency with increasing current injection.

At and below 0.88 nA, there is no continuous repetitive spiking.

At and above 7.7 nA depolarization blockade is seen.

- The greater the current, the greater the firing rate.
- Outside this range, there is no spiking.
- Below, there is a threshold for repetitive spiking.
- Above, spiking is blocked.

- The trace at the bottom of Fig. 12.10 (0.88 nA) illustrates activity just below the threshold for continuous repetitive spiking.
- Below 0.84 nA, this Hodgkin-Huxley model produces only one spike.
- (By this Hodgkin-Huxley model, I mean a parallel-conductance model using sodium and potassium channels parameterized using the Hodgkin-Huxley equations, but with different specific parameters describing the infinity and tau curves.)
- This model produces one spike all the way down to the spiking threshold, about 0.2 nA.

12-52

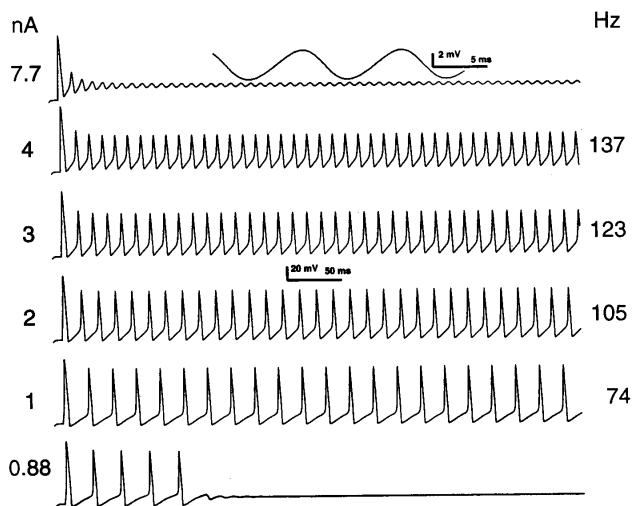

- On the other end, high current injections produce higher rates.
- The spikes become smaller and smaller.
- This contradicts what I said earlier about spikes being stereotyped and of constant amplitude.
- In fact, spike size does carry information about spike rate.
- It does not appear that this amplitude information is used however.
- In Fig. 12.10, a 4-nA current injection gives a measurable 137-Hz spike frequency.

- The spikes at this rate are only about half the size of the spikes produced by a 1-nA current injection.
- As we go to higher and higher injections, the spikes get less and less spike-like as we gradually pass over to the low-amplitude oscillation that is characteristic of depolarization blockade.
- Depolarization blockade occurs when the voltage gets so high that the h particle remains near 0.
- This means that the sodium channel does not deinactivate.
- Since the sodium channel is continuously inactivated, it is not possible to generate spikes.

12-53

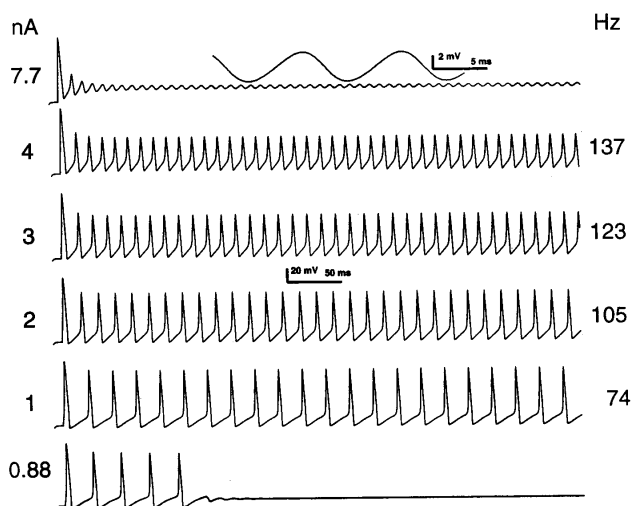

- For example, in the top trace, with 7.7 nA of injected current, the tiny oscillation has an amplitude of about 4 mV and frequency of about 165 Hz.
- Examination of state variables demonstrates that this oscillation is based on an interaction between V and m without substantial contribution from n and h .
- This is the dynamics of depolarization blockade, not the dynamics of neural spiking.

12-54

- Using the Hodgkin and Huxley model of neuron spiking, we can compare this realistic input/output (I/O) curve with the sigmoid (squashing) curve, the idealized input/output curve used in artificial neural network modeling (Fig. 12.11).

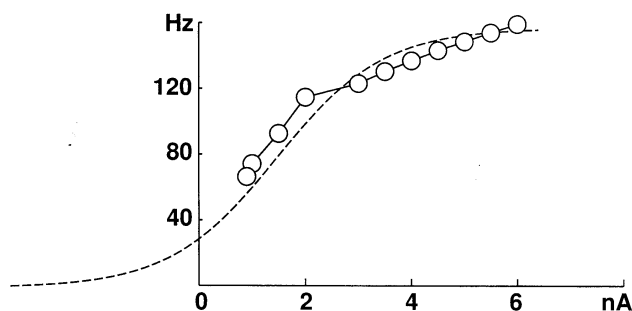

Fig. 12.11: An I-f curve from a Hodgkin-Huxley model compared to the standard sigmoid I/O curve of artificial neural networks.

- Both curves are monotonically increasing, meaning they only go up.
- Although it does not asymptote, the realistic I-f (current-frequency) curve in Fig. 12.11, like the sigmoid curve, does show some reduction in slope with higher input values.
- However, the sigmoid curve covers all input values, while the realistic I-f curve (current-frequency curve) only has outputs for a certain range of inputs.
- In math-speak, this means it has a limited domain (x-axis) and limited range (y-axis).
- Below this domain, there is a floor effect; above, there is a ceiling effect.
- By altering the Hodgkin and Huxley parameters we can move the ceiling, the floor, and the precise relationship between current and frequency.

12-55

- However, these measures are not independent, so that if you try to move the floor down, the ceiling and slope of the I-f relation (the gain) will change as well.
- This means that it is not possible to precisely tune a Hodgkin-Huxley model to produce exactly the response one might want for a particular network model.

12.9 Summary and thoughts

- The Hodgkin-Huxley model of the action potential is the most influential computer model in neuroscience and as such remains a touchstone of computational neuroscience.
- It's a dynamical model that arises from the interaction of four time-dependent state variables — V , m , h , and n .
- Of these only V , voltage, is directly measurable.
- The others are putative populations of switches that turn sodium and potassium channels on and off.
- Electrically, the Hodgkin-Huxley model is the basic membrane RC circuit with two conductances added in parallel.
- Hence the circuit is called the parallel-conductance model.
- The two added conductances are the active sodium and potassium conductances.
- These conductances are active because they change with change in voltage.
- A controllable resistance (conductance) is called a rheostat.
- Each of the conductances, including the passive “leak” conductance, is attached to a battery.
- The battery potential (voltage) depends on the distribution of the particular ion that flows through its own selective conductance.

12–57

- This Nernst potential is the electrical field that holds back the chemical flow of the ion across the membrane down its concentration gradient.
- The spike is the result of a set of interacting feedback loops.
- Depolarization activates sodium channels ($\uparrow m$) producing positive feedback with further depolarization.
This is the upswing of the spike.
- Following this, two negative feedback influences kick in.
The sodium channel starts to inactivate ($\downarrow h$).
Additionally, activation of the potassium channel actively pulls the potential back toward and past the resting membrane potential.
- The Hodgkin-Huxley model can be used to see how action potential behavior will influence neural signal processing and signal transduction.
- For example, the neuron has a threshold for action potential generation that can be altered by preceding inputs in a paradoxical way.
- An earlier excitatory input will raise the threshold, producing a late inhibitory influence.
- A preceding inhibitory input will lower the threshold, resulting in a relatively excitable state.
- Repetitive action potential firing is possible over only a limited range of inputs.
- Too little input produces no spikes or only a few spikes.

12–58

- Too much input produces depolarization blockade with a low amplitude oscillation.
- This limited range makes it difficult to use standard Hodgkin-Huxley model dynamics for rate coding in neural network models.
- Adding in the dynamics of other channels that are present in neurons makes it possible to get a wider range of firing frequency.