

Independence in Bayesian Networks

David Albrecht

Overview

- Terminology
- Semantics of Bayesian Networks
- Network Construction
- Blocking
- Independence
- Markov Blanket
- Decomposition of Joint Probability
- Inference in Dynamic Bayesian Networks

Independence of Events

- Let A and B be events.
- A and B are independent iff:

$$P(A \cap B) = P(A)P(B)$$

- If $P(B) > 0$ then A is independent of B, iff:

$$P(A | B) = P(A)$$

Independence of Random Variables

- Let X and Y be random variables.
- X and Y are independent iff for all values x of X and y of Y we have:

$$P(X = x, Y = y) = P(X = x)P(Y = y)$$

- We will often write this as follows:

$$P(x, y) = P(x)P(y)$$

Conditional Independence of Random Variables

- Let X, Y and Z be random variables.
- X and Y are conditional independent given Z iff for values of X, Y, and Z:

$$P(X=x, Y=y | Z=z) = P(X=x | Z=z)P(Y=y | Z=z)$$

- If $P(Y = y) > 0$ for all values of Y, then X is conditional independent of Y given Z, iff for all values of X, Y and Z:

$$P(X = x | Y = y, Z = z) = P(X = x | Z = z)$$

Semantics of Bayesian Networks

- A compact representation of the joint probability distribution.
 - Useful in designing inference procedures.
- An encoding of a collection of conditional independence statements.
 - Useful in understanding how to construct networks.

Network Construction

- Choose a set of relevant variables that describe the domain.
- Choose an ordering of the variables.
 - Best to choose the root causes, then the variables they influence.
- While there are variables which have not been added to the network:
 - Pick the next variable x_k .
 - Set the parents of x_k to be the minimal set pa_k of the variables in the network x_1, \dots, x_{k-1} such that:

$$P(x_k | x_1, \dots, x_{k-1}) = P(x_k | pa_k)$$

Blocking

- A path p from a node X to a node Y is said to be *blocked* by a set of nodes E if there is a node Z on the path such that one of the following conditions hold:
 - Path p contains a chain node $\rightarrow Z \rightarrow$ node or a fork node $\leftarrow Z \rightarrow$ node, and Z is in E .
 - Path p contains a collider node $\rightarrow Z \leftarrow$ node, and Z is not in E and no descendants of Z are in E .

Blocking

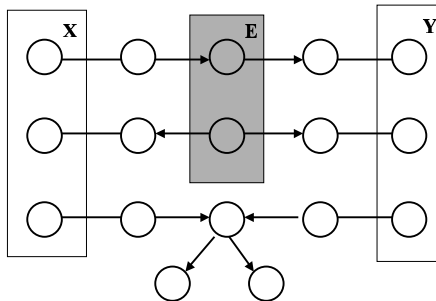

Independence

Theorem: In a Bayesian Network the random variables X and Y are conditionally independent given a set of variables E if and only if E blocks all paths from X to Y .

Inference in Temporal Networks

- Prediction**
 - Computing the belief of future states given all the evidence to date.
- Filtering**
 - Computing the belief of the current state given all the evidence to date.
- Smoothing**
 - Computing the belief of a past state given all the evidence to date.

Umbrella World

$$P(r_{n+1} | r_n) = 0.7$$

$$P(r_{n+1} | \neg r_n) = 0.3$$

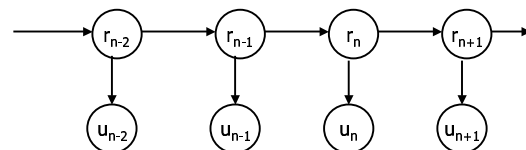

$$P(u_n | r_n) = 0.9$$

$$P(u_n | \neg r_n) = 0.2$$