

Chapter 4: Threads





Chapter 4: Threads

- Overview
- Multithreading Models
- Threading Issues
- Pthreads
- Windows XP Threads
- Linux Threads
- Java Threads





Single and Multithreaded Processes

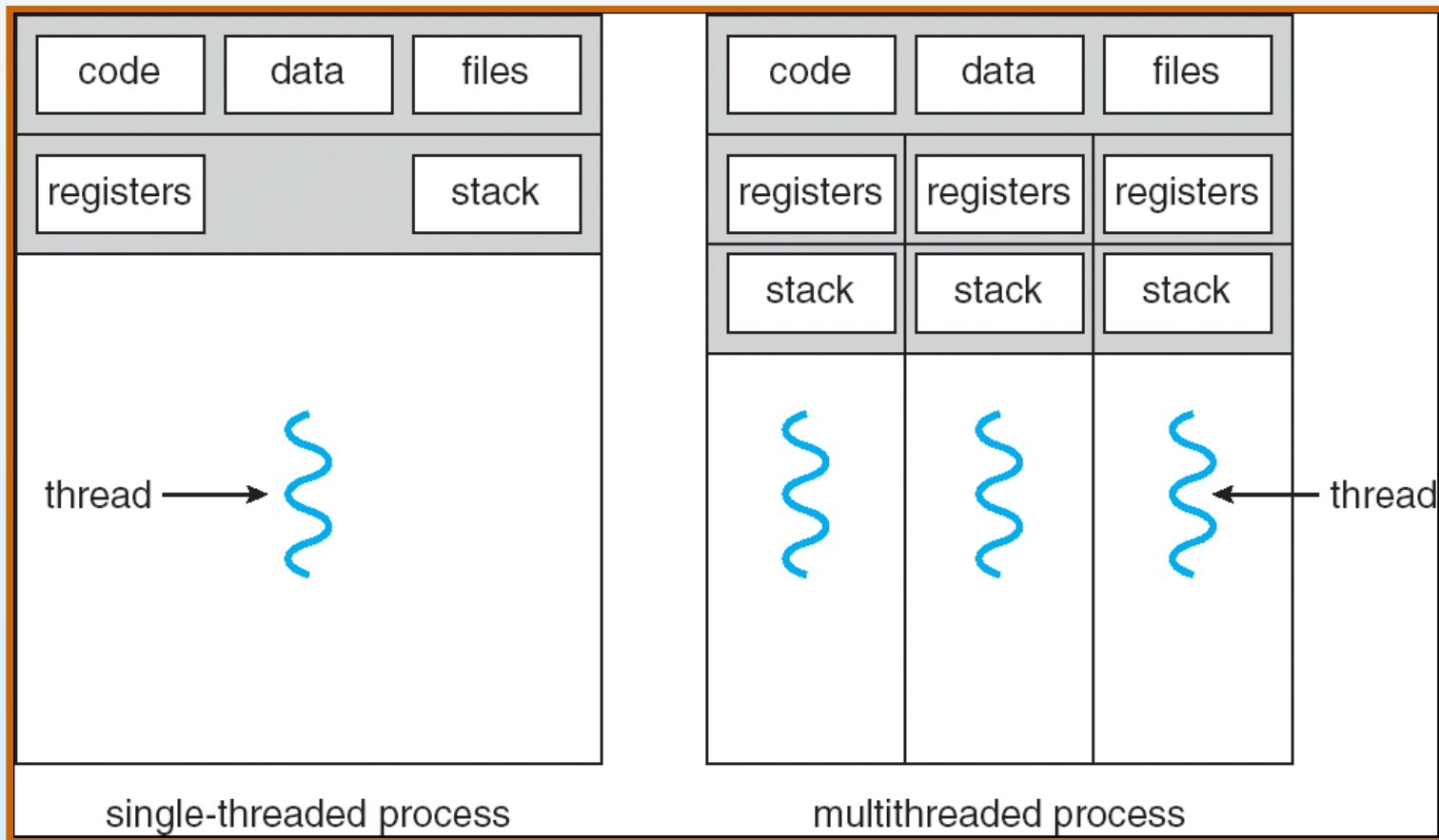



Benefits

- Responsiveness
- Resource Sharing
- Economy
- Utilization of MP Architectures





User Threads

- Thread management done by user-level threads library

- Three primary thread libraries:
 - POSIX Pthreads
 - Win32 threads
 - Java threads





Kernel Threads

- Supported by the Kernel

- Examples
 - Windows XP/2000
 - Solaris
 - Linux
 - Tru64 UNIX
 - Mac OS X





Multithreading Models

- Many-to-One
- One-to-One
- Many-to-Many





Many-to-One

- Many user-level threads mapped to single kernel thread
- Examples:
 - Solaris Green Threads
 - GNU Portable Threads





Many-to-One Model

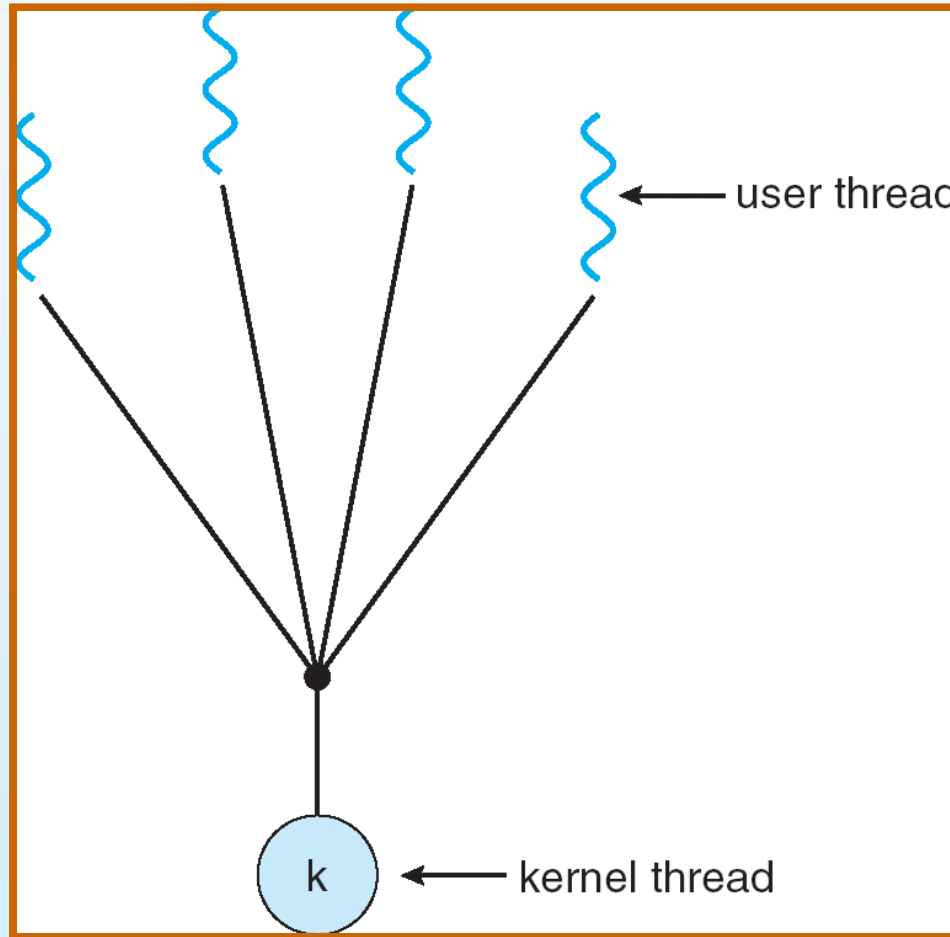



One-to-One

- Each user-level thread maps to kernel thread
- Examples
 - Windows NT/XP/2000
 - Linux
 - Solaris 9 and later





One-to-one Model

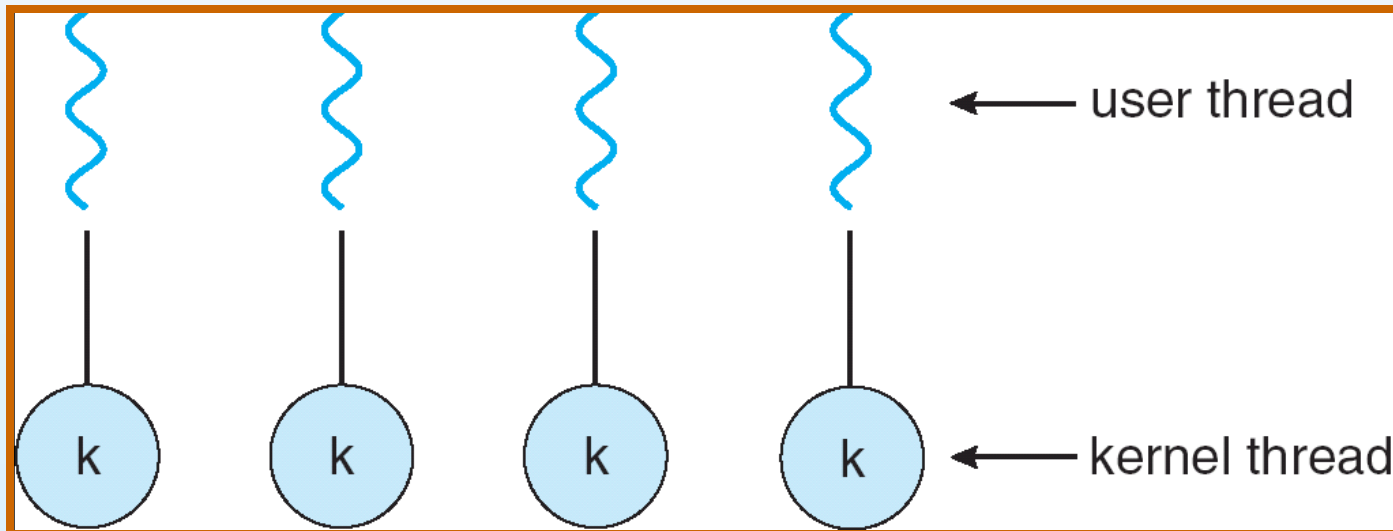



Many-to-Many Model

- Allows many user level threads to be mapped to many kernel threads
- Allows the operating system to create a sufficient number of kernel threads
- Solaris prior to version 9
- Windows NT/2000 with the *ThreadFiber* package





Many-to-Many Model

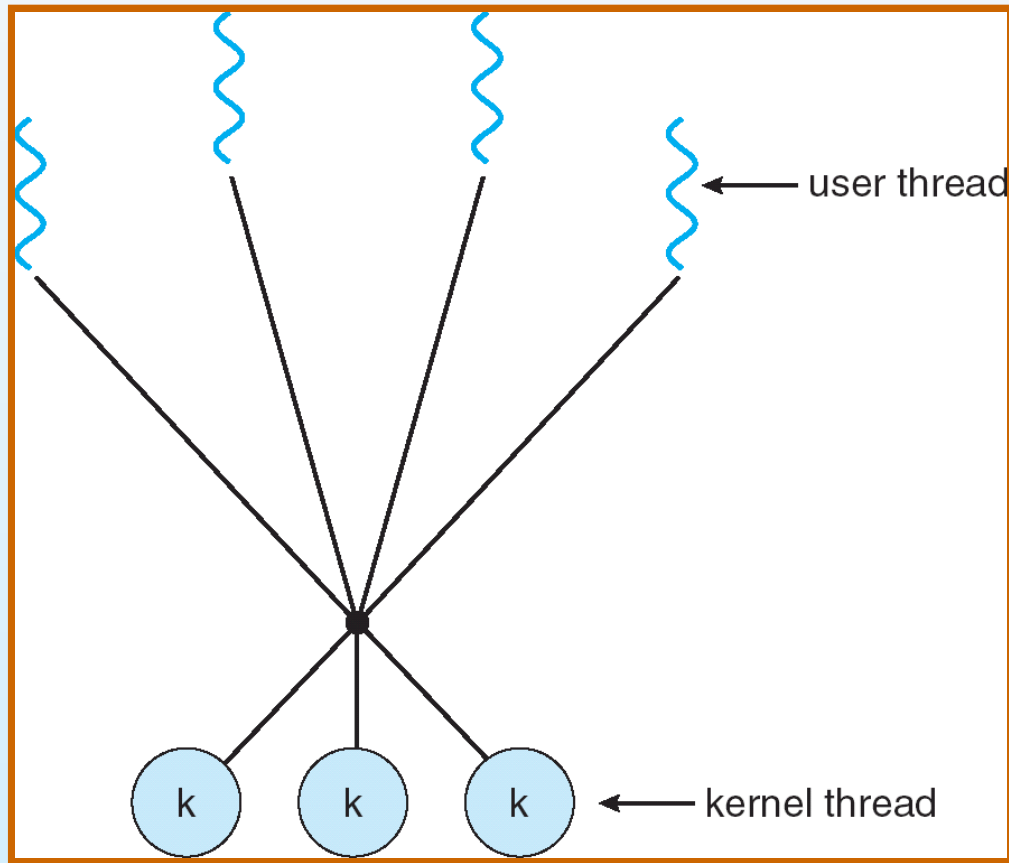



Two-level Model

- Similar to M:M, except that it allows a user thread to be **bound** to kernel thread
- Examples
 - IRIX
 - HP-UX
 - Tru64 UNIX
 - Solaris 8 and earlier





Two-level Model

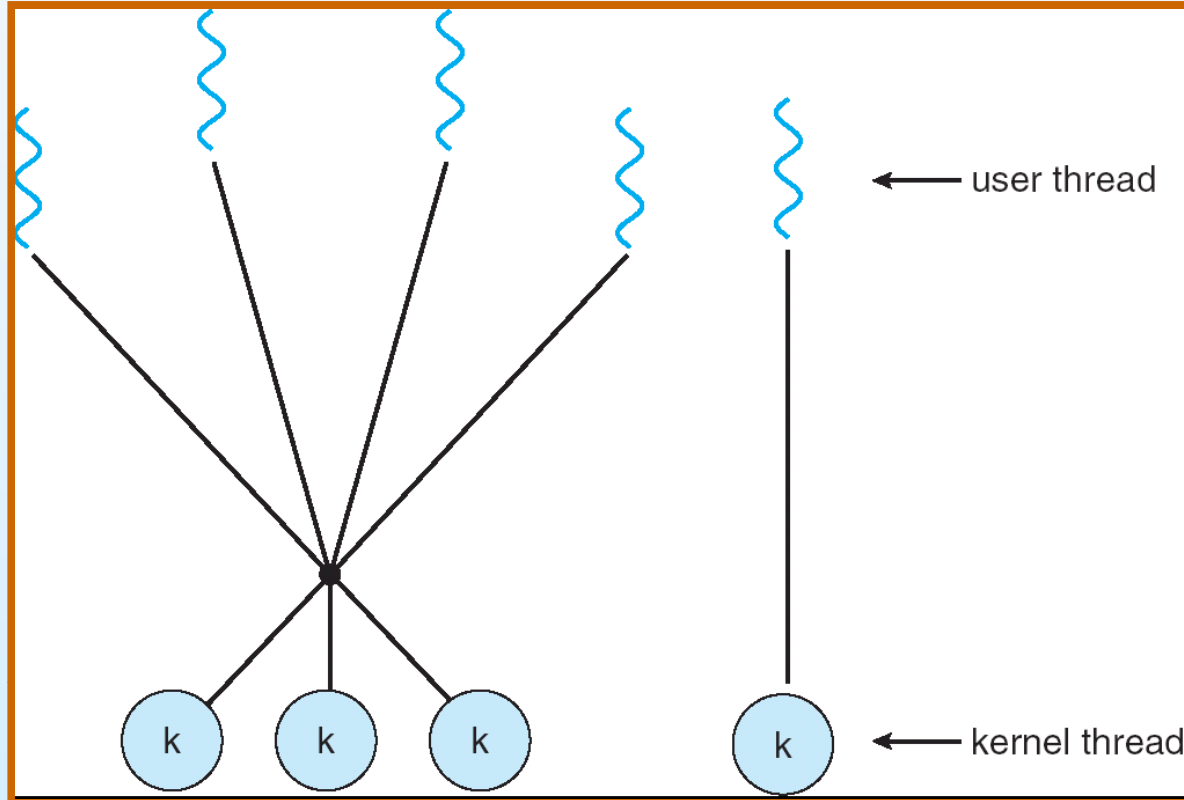



Threading Issues

- Semantics of **fork()** and **exec()** system calls
- Thread cancellation
- Signal handling
- Thread pools
- Thread specific data
- Scheduler activations





Semantics of `fork()` and `exec()`

- Does `fork()` duplicate only the calling thread or all threads?





Thread Cancellation

- Terminating a thread before it has finished
- Two general approaches:
 - **Asynchronous cancellation** terminates the target thread immediately
 - **Deferred cancellation** allows the target thread to periodically check if it should be cancelled





Signal Handling

- Signals are used in UNIX systems to notify a process that a particular event has occurred
- A **signal handler** is used to process signals
 1. Signal is generated by particular event
 2. Signal is delivered to a process
 3. Signal is handled
- Options:
 - Deliver the signal to the thread to which the signal applies
 - Deliver the signal to every thread in the process
 - Deliver the signal to certain threads in the process
 - Assign a specific thread to receive all signals for the process





Thread Pools

- Create a number of threads in a pool where they await work
- Advantages:
 - Usually slightly faster to service a request with an existing thread than create a new thread
 - Allows the number of threads in the application(s) to be bound to the size of the pool





Thread Specific Data

- Allows each thread to have its own copy of data
- Useful when you do not have control over the thread creation process (i.e., when using a thread pool)





Scheduler Activations

- Both M:M and Two-level models require communication to maintain the appropriate number of kernel threads allocated to the application
- Scheduler activations provide **upcalls** - a communication mechanism from the kernel to the thread library
- This communication allows an application to maintain the correct number kernel threads





Pthreads

- A POSIX standard (IEEE 1003.1c) API for thread creation and synchronization
- API specifies behavior of the thread library, implementation is up to development of the library
- Common in UNIX operating systems (Solaris, Linux, Mac OS X)





Windows XP Threads

- Implements the one-to-one mapping
- Each thread contains
 - A thread id
 - Register set
 - Separate user and kernel stacks
 - Private data storage area
- The register set, stacks, and private storage area are known as the **context** of the threads
- The primary data structures of a thread include:
 - ETHREAD (executive thread block)
 - KTHREAD (kernel thread block)
 - TEB (thread environment block)





Linux Threads

- Linux refers to them as *tasks* rather than *threads*
- Thread creation is done through **clone()** system call
- **clone()** allows a child task to share the address space of the parent task (process)





Java Threads

- Java threads are managed by the JVM

- Java threads may be created by:
 - Extending Thread class
 - Implementing the Runnable interface





Java Thread States

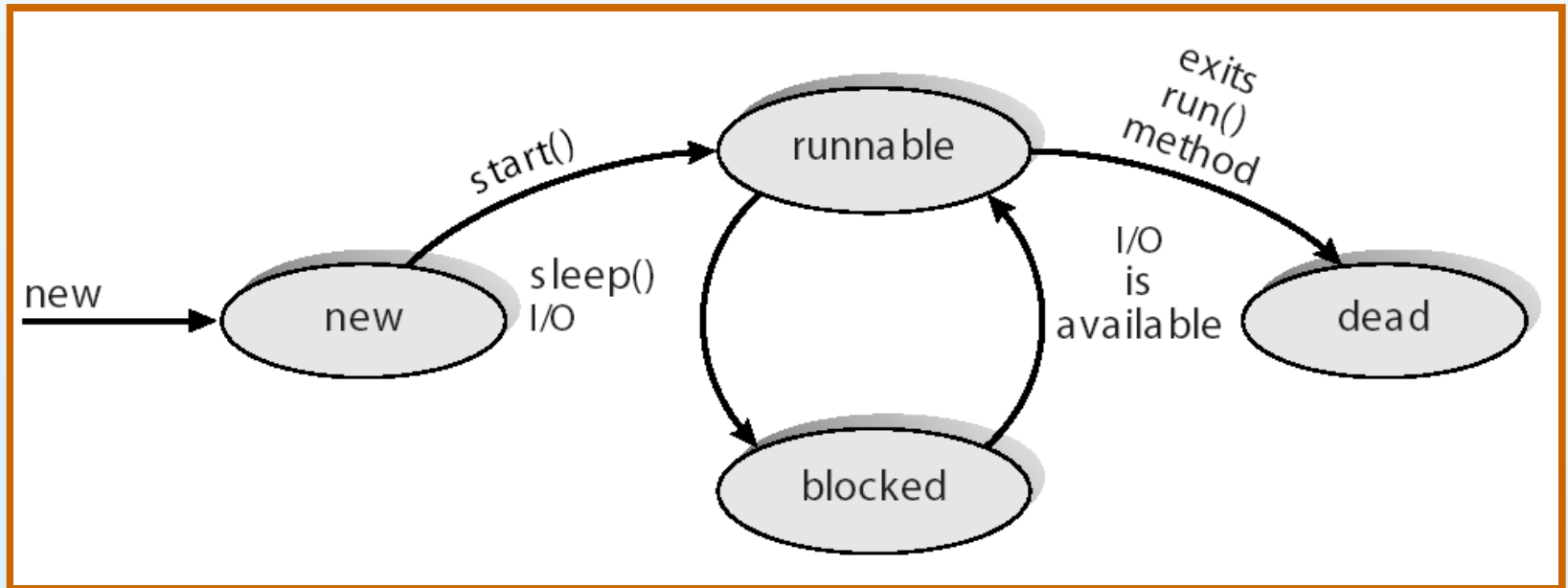

End of Chapter 4

