

FIT2022 Tutorial 2

1. Objectives and Outcomes

1.1 Objectives

1. to review material covered in the introductory lectures (Nutt chapters 1-4);
2. to review understandings of concepts such as Processes, Events, Interrupts required for Lab2;
3. to answer questions arising from lectures during the first few weeks;

1.2 Outcomes

1. you should be able to describe the purpose of various operating system components;
2. you should be able to explain what is happening in a Multiprogramming System; and
3. you should be able to articulate the learning you have achieved over the first two weeks of this unit.

2. The Basics

1. State one model or paradigm of operating system philosophy
2. Should operating systems always make the most efficient use of the computing hardware? Under what circumstances might this paradigm be broken?
3. What are the advantages and disadvantages of multiprogramming?
4. What is the difference between *multiprogramming* and *multiprocessing*?
5. What are the security implications of multiprogramming? Explain how the dual mode supervisor/user mode paradigm provides security in this context.
6. Explain what is happening in the Multiprogramming System figure shown in slide 1-19, and reproduced here

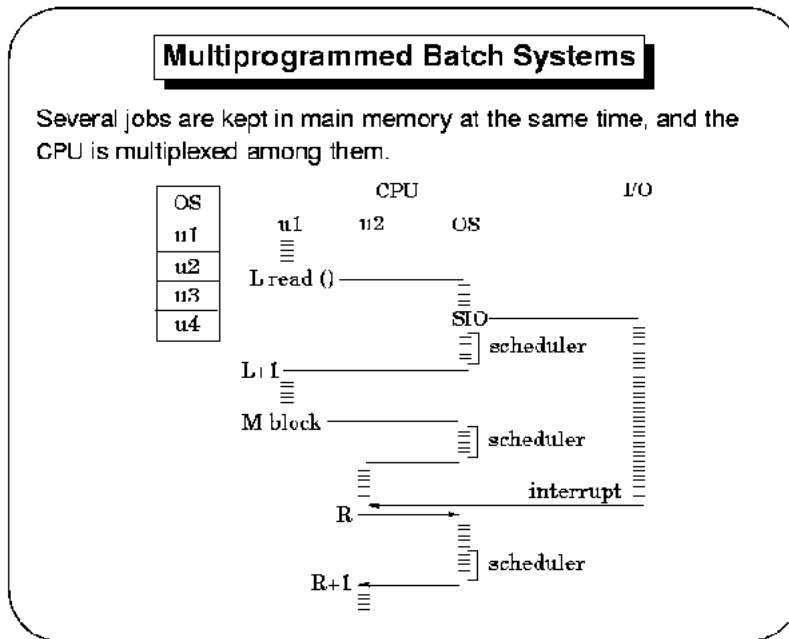

3. Operating System Structures

1. List the services an operating system provides for the programs that execute under its control.
2. Name some operating system calls that you have used. What system calls might be generated by a command line interpreter or shell?
3. Name some I/O devices that might be shared (without interference) between two active processes. For example, a scanner could not be shared, as there is only one physical image present in/on the scanner at a time.
4. Figure 3.5 from SGG (reproduced below) shows the memory model differences between message passing and shared memory forms of inter-process communication. Identify which method would be better if the processes reside in different computer systems, and explain why.

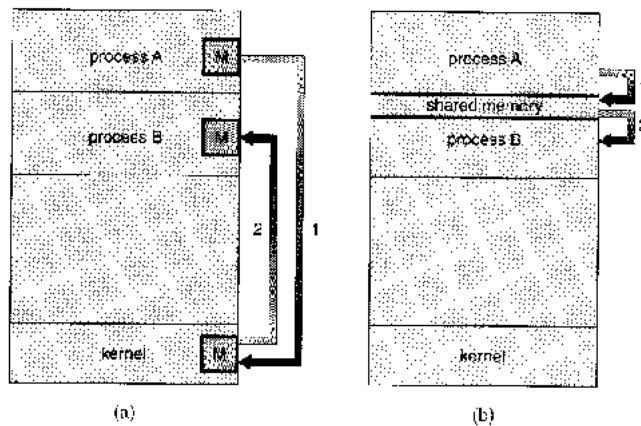

Figure 3.5 Communications models. (a) Msg passing. (b) Shared memory.

5. One approach to the design of an operating system is to build the components of the system in *layers*, where components in each layer m depend upon the resources and operations provided by components at the next lower level $m-1$. The hardware is then regarded as layer 0 . What advantages can you think of for this approach?

4. Lab 1 and your Laboratory Journal

Print out your laboratory journal from Lab 1 and bring it to the tutorial. Alternatively, write down a list of things that you learnt in the lab session (if you haven't written up your lab journal from last week, you should enter your experiences into your journal and save it using the SVN server during this week.) Discuss what you have learnt, and share with the class common and different experiences (write these up on the whiteboard).

5. Any Other Issues

Are there any other issues you would like to discuss?